

INSTRUCTION MANUAL ACCESSORIES

ENGLISH

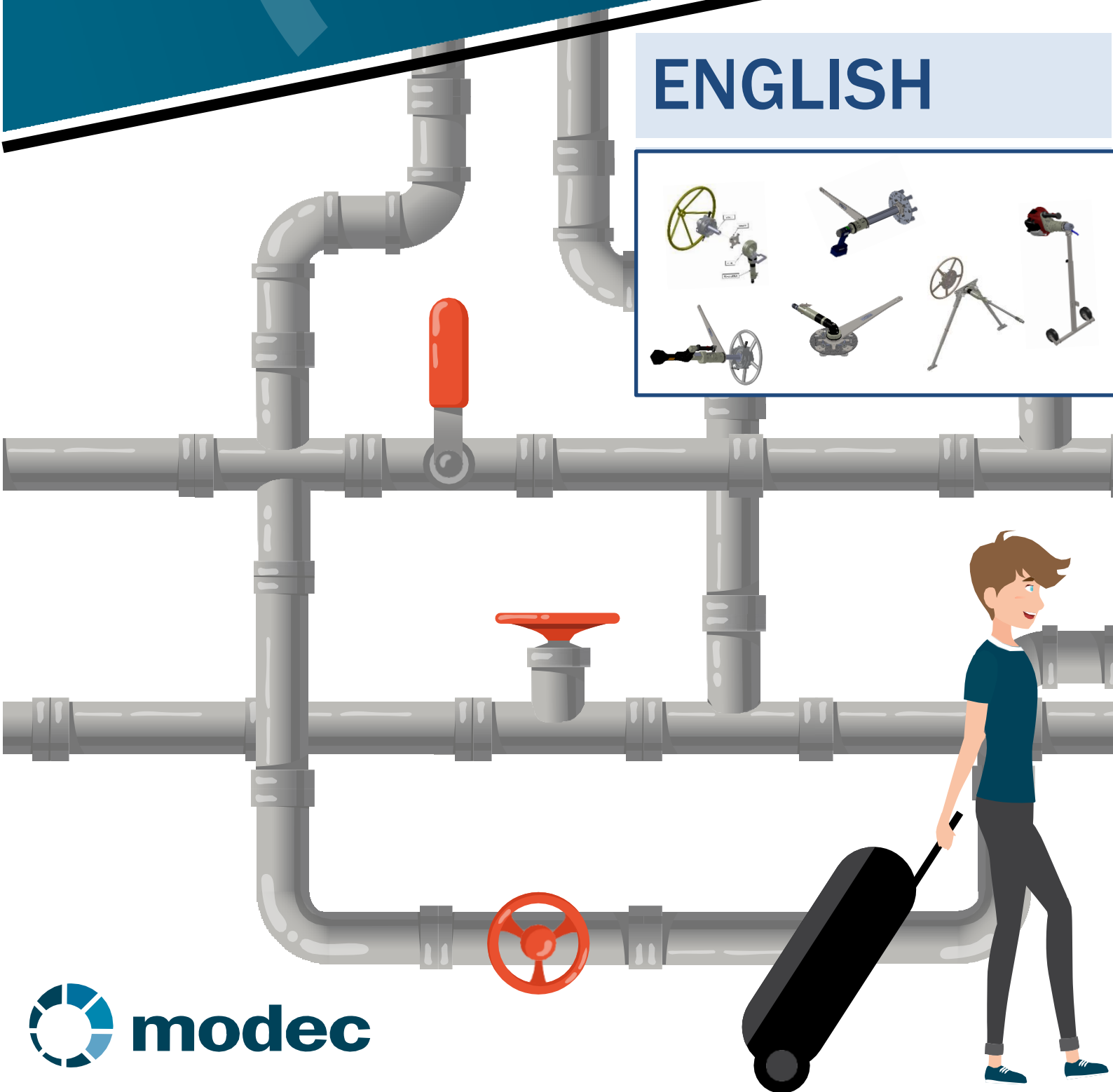

Table of content

Portable Valve Actuators	3
1. Instruction manual	3
2. Introduction.....	4
3. General safety warnings	5
a. Transporting the actuator.....	7
b. Storing the actuator	7
c. Protecting the environment.....	7
4. Instruction Manual : modec Portable Valve Actuators.....	7
5. CE certification.....	8
6. Safety equipment	9
7. Actuators drive heads	9
a. Standard Duty Banjo head BJH01	9
b. Heavy Duty Banjo head BJH02	10
c. RA30 right angle drive head.....	10
8. Adapters	11
a. Self-adjusting and self-centering fingers adapters (SAxxx).....	11
b. Fixed fingers adapters SUAxxx	14
c. Spoke Adapters for flat handwheels FSBxxx.....	17
d. Spoke adapters for tapered handwheels CSBxxx.....	21
e. Fixed universal adapters FUAxxx.....	23
9. Accessories	27
a. Handwheel protectors for use with SAxxx adapters.....	27
b. Square drives	27
c. Telescopic valve key	30
d. Interface for use of the telescopic valve key with a BJH	30
10. Torque management systems	32
a. Single reaction arm BR001	32
b. Double reaction arm BR002	32
c. Reaction arm for Banjo head BR003	32
d. Articulated reaction arm fixed to vehicle trailer hatch BA001.....	33
e. Foot held articulated reaction arm BA002.....	34
f. Stand for underground / buried valves SE001.....	35
g. Telescopic bipod BP001.....	36
Warranty	37

Portable Valve Actuators

Adapters, interfaces and accessories

1. Instruction manual

modec Portable Valve Actuators offer improved safety and comfort for operators and protect equipment from damage. They can be adapted to all types of handwheels, keys and valves, with a torque range that can reach up to 1000Nm.

This instruction manual describes the way adapters, interfaces and accessories should be used for a maximum comfort, efficiency and safety.

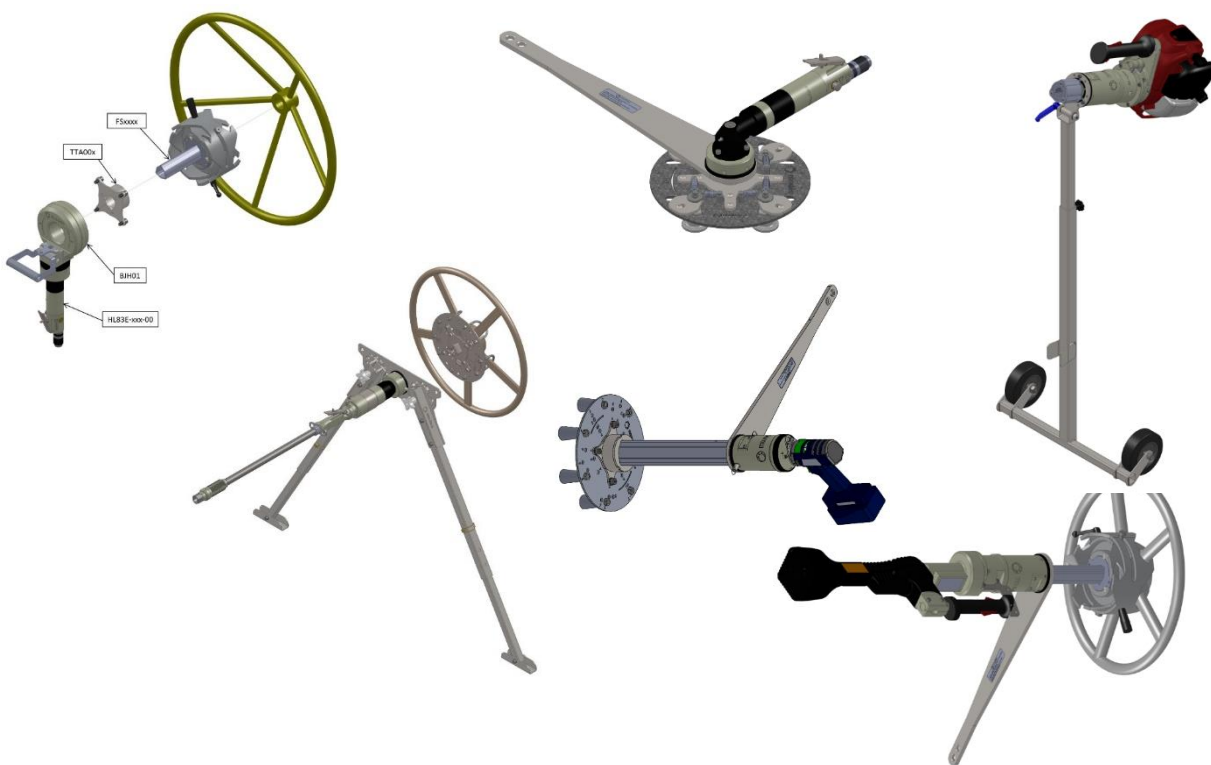

CAREFULLY READ THE INSTRUCTION MANUAL BEFORE USE



2. Introduction

This instruction manual must always be available and kept close to where the actuator will be used.

This document is unique and is owned by the company **modec**. It cannot be corrected, modified or duplicated without prior written agreement. This document should not be considered a replacement for safety rules set out in the Work Code or in any other legislation that applies to the site where the actuator is used.

It belongs to the operators to make sure that all security regulations applicable to both the work site and the Portable Valve Actuator conditions of use are respected.

modec products are conceived and fabricated with the utmost care and attention for the safety of both the operator and the equipment. This is certified by the declaration of conformity with the relevant clauses in the European directive 2006/42/CE.

The actuators described in this document may evolve. We reserve the right to modify their specifications, without prior notice. Updates will be available on our website www.modec.fr. It is important to refer to the website before setting up or using the actuator, and before carrying out maintenance. Any modifications made to the actuators or their accessories must be approved in writing by **modec**.

Operators in charge of setting up, using or servicing **modec** actuators must have a reasonable knowledge of the equipment. As well as carefully reading this instruction manual, they must be competent in the valve sector and the particularities related to their work environment.



KEEP THESE INSTRUCTIONS

This manual contains important information and user instructions for adapters, interfaces and accessories used with the following tools: Pneumatic Portable Valve Actuator HL83x-xxx-xx, Petrol gas PY68x-xxx-xx, Electric JA73x-xxx-xx and Electric MC89x-xxx-xx.

It is **IMPERATIVE** that you read the whole of this user guide before using the tool or carrying out any maintenance operations. Make sure you follow to the letter the instructions and diagrams found in this document. Failure to adhere to the instructions contained in this manual, and any modifications, omissions or the use of replacement parts that do not adhere to the specifications set out in this manual, clears the manufacturer of all responsibility related to the protection of people and equipment.



3. General safety warnings

This machine is not intended for use by people with reduced physical, sensory or mental capacity, or by people devoid of experience or knowledge, except if they are supervised by, or have been given instructions by, an intermediary for the person responsible for their security. Portable Valve Actuators are designed solely for use by professional operators trained in how to use them and educated about the relevant safety measures.



To avoid all risk of injury associated with using a **modtec** Portable Valve Actuator, take care to always follow the user instructions. Make sure you work in a comfortable position that demands minimal effort from your body, arms and wrists. Keep your wrists straight, without excessive, repetitive or prolonged twisting or extension. Do not use force and do not hold the tool tighter than necessary – avoid long exposure to vibrations.

- The **modtec** Portable Valve Actuator is a tool whose use is exclusively for manipulating valve handwheels or rotating systems, such as those described in this document.
- **modtec** Portable Valve Actuators are not adapted for manipulating winches or lifts.
- The company **modtec** declines all responsibility for damages caused by incorrect use and any use other than the one intended.
- The company **modtec** also declines all responsibility for damages resulting from the use of accessories that are not the original.

Work zone safety

- Keep the work area clean and well-lit – minimum level lighting of 300 lux
- Aside from the operator, keep any other people at a safe distance within a radius that takes account of fixed points, straps, chains and any other torque retention system used.
- To protect the operator, we recommend that you do not use the PVAs if there is a risk of lightning.

Safety of personnel during use and maintenance

- Stay vigilant – watch what you are doing and apply common sense when using the tool. Don't use a tool if you are tired or under the influence of drugs, alcohol or medicines.
- Use the individual safety protection equipment (see the summary table, page 6).
- Do not rush ahead – maintain a suitable position and balance at all times.
- Wear suitable clothing – do not wear baggy clothes or jewelry. It is obligatory to tie back hair and to wear close-fitting clothes (not floaty) to ensure all clothing parts are distanced when moving.
- To avoid the motor starting at the wrong time, before picking up or while carrying the PVA:
 - Pneumatic PVA: Withdraw the actuator power feed
 - Electric PVA: Remove or disconnect the battery
 - Petrol gas PVA: Place the cursor in the 0 position. Even better, disconnect the spark plug

Use and servicing

- Do not use the tool if the switch systems for changing direction, accelerating, starting up or stopping are not working properly. This could pose danger to the operator.
- Observe tool maintenance. Check there if no incorrect alignment or blockage of moving parts or from broken parts or any other problem that could affect how the tool functions. If there is any damage, take the necessary steps and precautions to return the tool and its accessories to good working order.
- Have the tool serviced by a qualified repairer using only **modec** products when changing parts.
- Only use valve accessories recommended and approved by **modec**. Think to consult the accessory list provided and/or seek advice from **modec** for specific uses.
- Before starting up the motor, the operator must, without fail, check the follow points:
 - Accessories mounted or activated by the actuator are in good condition and correctly attached.



- The spring retaining button situated on the actuator and right angle head (RA30) output shafts is designed to support the weight of the adapters, not the weight of the actuator. Therefore, do not carry an adapter + actuator assembly by the adapter. Do not allow the actuator to hang down simply by being held by this spring retaining button. Doing so may cause the actuator to fall, become damaged or cause serious injury to the operator.
- The most suitable torque retention system is being used and it assures the safety of the operator.
- The system that fixes to the valve or the handwheel is adapted to the valve or handwheel being actuated.
- Both the actuator and the operator are in a stable position. The operator is placed in opposition to any possible movements the actuator may make while coming to a stop.
- Stop the actuator immediately if it starts to behave differently (a change of noise, increased vibrations). Replace all damaged parts of the actuator and accessories. Damaged parts can burst and cause serious harm, even a potential fatality.
- Before placing a handwheel on, or removing it from, the actuator, wait until the actuator has come to a complete stop.
- Only activate the command to inverse the direction left/right when the actuator is fully stopped, otherwise the operator may find they are working in a poorly adapted position.

- For the mechanical direction invertors (HL83, PY68, MC89), always hold down the switch until it stops.

 In certain circumstances, the tool may keep rotating for several seconds after releasing the switch. Never put your hands close to the tool or any moving parts.

- Do not open the battery. Risk of short-circuiting.
- Protect the battery from heat, for example direct exposure to the sun, to fire, to water and to humidity. There is a risk of explosion.
- In case of damage or non-conforming use of the battery, vapors could escape. Ventilate the work place and consult a doctor if you feel unwell.

a. Transporting the actuator

- General instructions for all actuators:
 - Keep the original casing for return in case of any revisions or repairs.
 - When packing, make sure that all switches are off and without any constraints.
 - Always pack the tools in the correct spaces to avoid them knocking against each other.
 - Petrol gas PVA – Empty the petrol and oil tanks.
 - Electric PVA – Replace the batteries in their allotted casing.
 - Lithium-ion batteries are subject to rules regulating the transport of dangerous materials. The operator can transport the batteries by road without taking any additional measures.
 - When transporting via a third party (for example, by air or a via a transport company), you must conform to the specific measures regarding packaging and labelling. In such a case, it is imperative to take advice from an expert in the transport of dangerous materials when preparing the transportation. Only send the batteries if the packaging is not damaged. Recover any unprotected contacts and pack the batteries tightly so they cannot move about. Please also follow any additional regulations that may apply.

b. Storing the actuator

- **modec** actuators must be stored in a dry and correctly ventilated environment to ensure there is no corrosion of the internal mechanic parts.

c. Protecting the environment

To eliminate waste, conform to the stated national requirements. The actuators and their accessories must not be thrown in a waste bin. Make sure you dispose of the tools in specialist recycling centers.

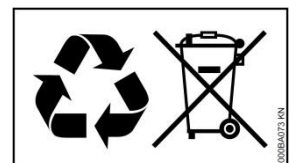

4. Instruction Manual : modec Portable Valve Actuators

The Portable Valve Actuators user's manual videos

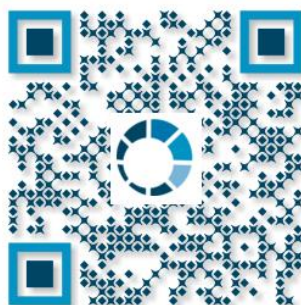

5. CE certification

CERTIFICATE OF  COMPLIANCE (Annex II A)

The undersigned manufacturer

MODEC SAS
ZI Sirius Quatre, 80 allée René Higonnet
F-26760 Beaumont lès Valence
N° SIRET : 493 748 917 00017

Declares that the Portable Valve Actuator designated by the following commercial references:

Type Designation Serial number

Pneumatic

HL83E-xxx-xx	Air Portable Actuator, Easy Duty,	XXXXXXXX
HL83S-xxx-xx	Air Portable Actuator, Standard Duty	XXXXXXXX
HL83H-xxx-xx	Air Portable Actuator, Heavy Duty	XXXXXXXX

Petrol gas

PY68E-xxx-xx	Gas Portable Actuator, Easy Duty	XXXXXXXX
PY68S-xxx-xx	Gas Portable Actuator, Standard Duty	XXXXXXXX
PY68H-xxx-xx	Gas Portable Actuator, Heavy Duty	XXXXXXXX

Electric

MC89E-xxx-xx	Electric Portable Actuator, Easy Duty	XXXXXXXX
MC89S-xxx-xx	Electric Portable Actuator, Standard Duty	XXXXXXXX
JA73E-xxx-xx	Electric Portable Actuator, Easy Duty	XXXXXXXX
JA73S-xxx-xx	Electric Portable Actuator, Standard Duty	XXXXXXXX
JA73H-xxx-xx	Electric Portable Actuator, Heavy Duty	XXXXXXXX

complies with the essential requirements of the European Directive 2006/42/EC

Type : S/N

Beaumont lès Valence,
XX/XX/XXXX
Mr. Pierre-Yves COTE
Managing Director
Signature :

6. Safety equipment

Personal Protective Equipment:

Operators or anyone placed close to the actuators must wear the following protections. It is incumbent on the company using the equipment to ensure that safety rules are respected.



Hearing protection



Protective goggles



Safety shoes



Safety gloves (level 3121 according to EN388)



Caution, the use of the material can be dangerous



Before use, **read the instructions**



Risk of fire



Do not expose or work in the rain

7. Actuators drive heads

The actuators drive heads are suitable for use with all the adaptors in the **modec** range.

a. Standard Duty Banjo head BJH01

The BJH01 ring-type drive head allows a rising stem to pass through the center of the handwheel to maneuver within a diameter of up to 63 mm. It adds a reduction ratio of 4 to the tool. The maximum output torque allowed is 600 Nm.

It can only be used with the following actuators:

- JA73E, JA73S-077
- HL83E, HL83S-035
- PY68E, PY68S-087
- MC89E/S with a proper torque limit setting (see MC89 instruction notice and sticker on the product)

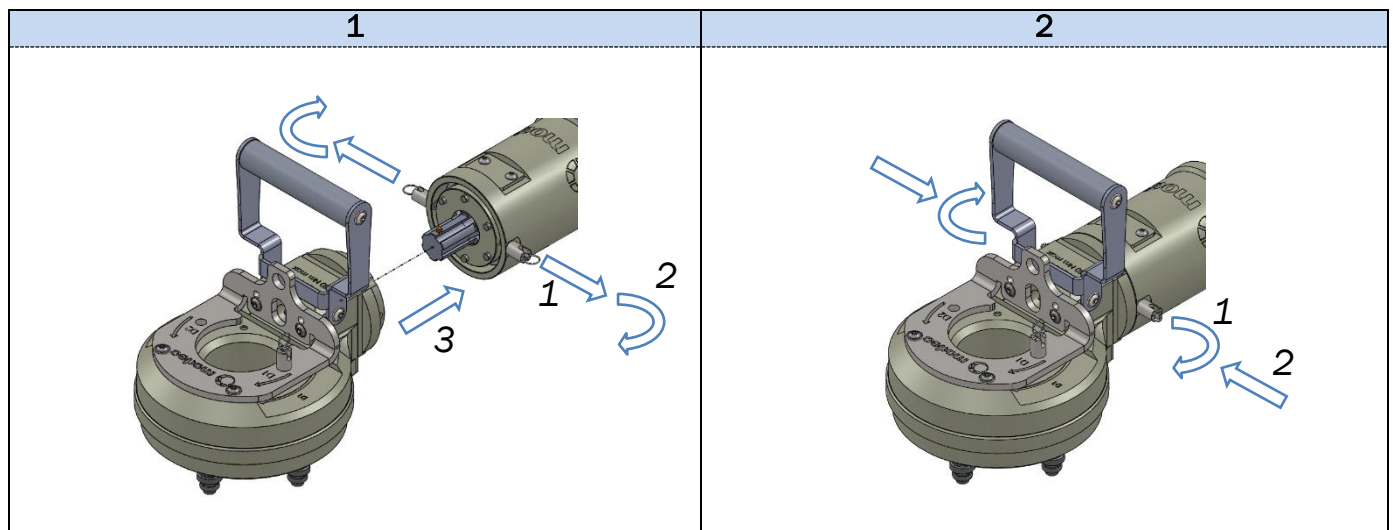

b. Heavy Duty Banjo head BJH02

The BJH02 ring-type drive head allows a rising stem to pass through the center of the handwheel to maneuver within a diameter of up to 70 mm. It adds a reduction ratio of 3 to the tool. The maximum output torque allowed is 900 Nm.

It can only be used with the following actuators:

- JA73E/S/H-169
- HL83E/S/H-111
- PY68E/S/H-192
- MC89E/S-077 with a proper torque limit setting (see MC89 instruction notice and sticker on the product)

-> See the diagram at the bottom of page 9.

c. RA30 right angle drive head

The RA30 can be used with all adaptors, torque retention systems and accessories in the **modec** range.

Its maximum admissible torque is 600 Nm. It can be used with all **modec** portable valve actuators, **except** :

- JA73H-564
- HL83H-321
- PY68H-641
- MC89S-077 unless the torque limit is set to 600 Nm max (see MC89 instruction notice and sticker on the product)

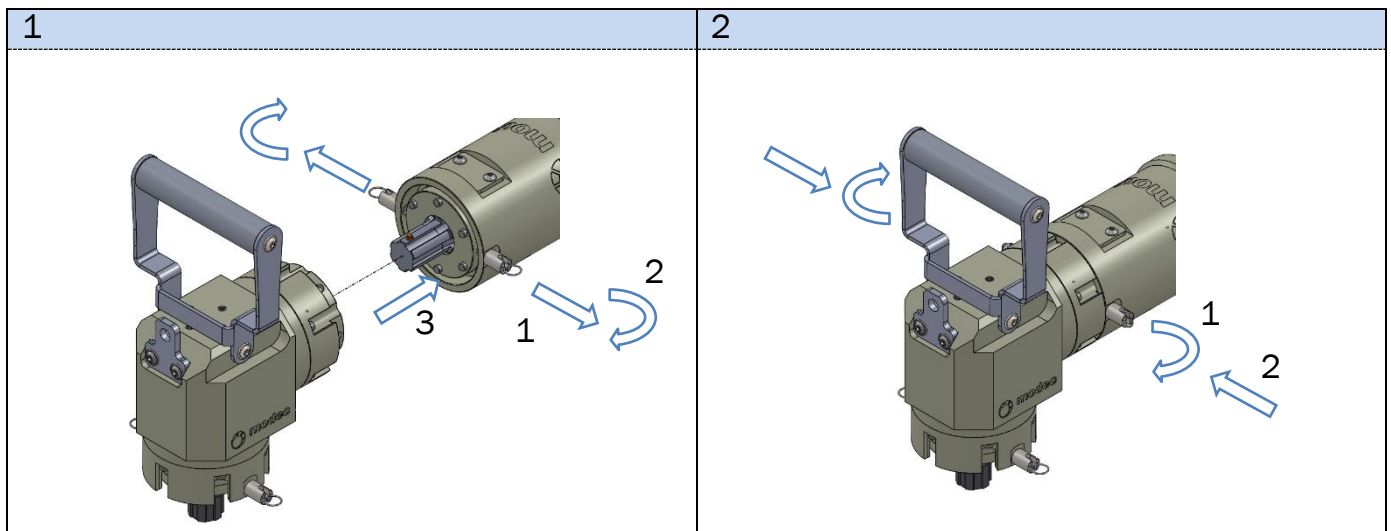

8. Adapters

Actuators heads can be used with all **modec** adapters.

a. Self-adjusting and self-centering fingers adapters (SAxxx)

Adapter	Maximum admissible torque (Nm)	Handwheel number of spokes	Handwheel type	Minimum handwheel \varnothing (mm)	Maximum handwheel center \varnothing (mm)	Assembly
SA003	350	3 / 6	Flat or moderately tapered (The angle between the spokes and the wheel plane doesn't exceed 10°) WITH or WITHOUT rising stem (max \varnothing : 58 mm)	157	53	Banjo head BJH (with or without rising stem)
SA004	2 spokes \rightarrow 350 \geq 4 spokes \rightarrow 1000	2 / 4 / 8		237	133	
SA005	1000	5		241	137	OR modec standard flange & shaft with the KPAXxx interface (no rising stem)
SA006	1000	3 / 6		277	173	
SA007	1000	7		301	192	



SA003



SA004



SA005



SA006



SA007

• ASSEMBLY ON A modac STANDARD FLANGE & SHAFT

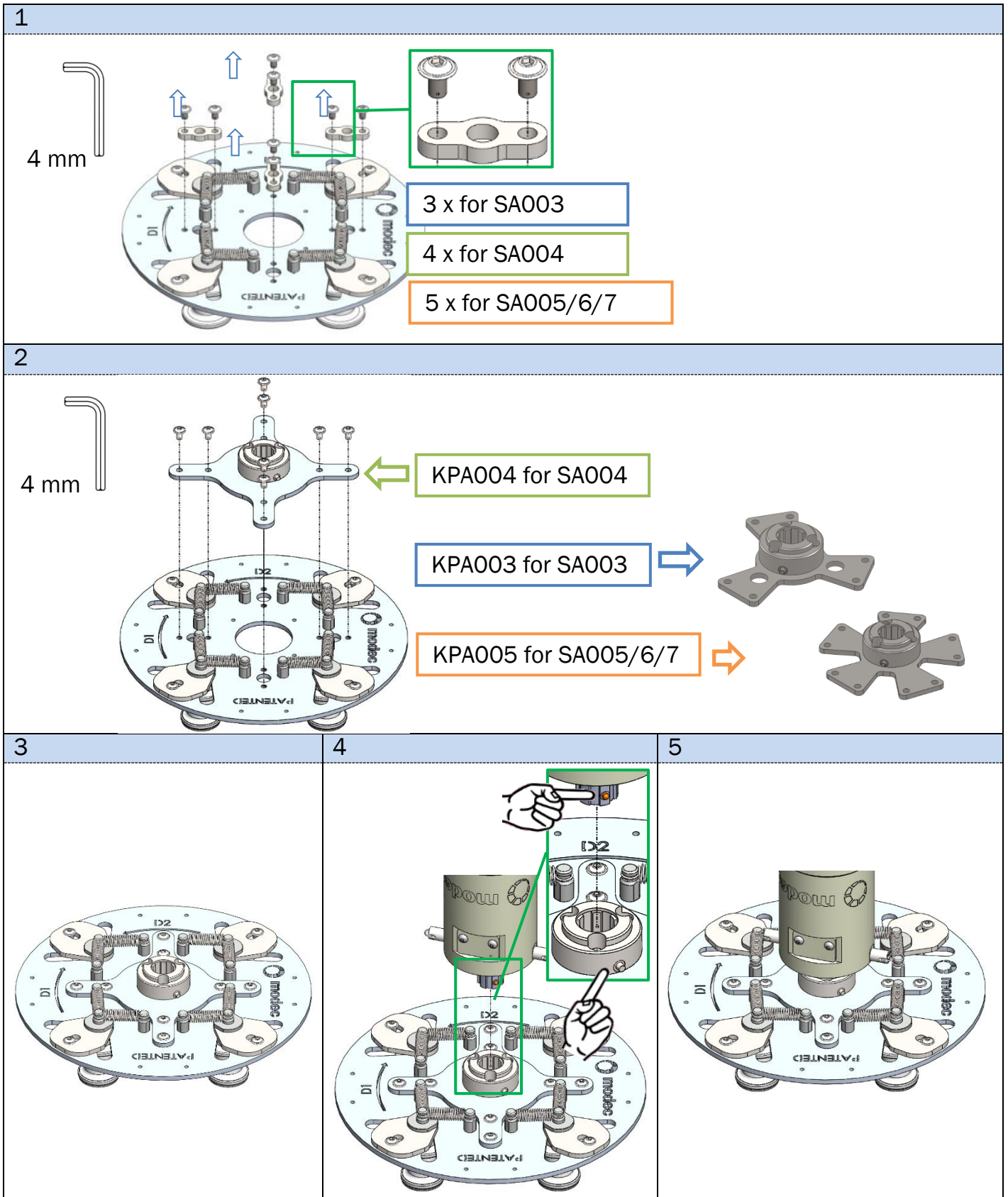

• **ASSEMBLY ON A BANJO HEAD**

<p>1</p> <p>15 mm</p> <p>3 pegs for SA003</p> <p>4 pegs for SA004</p> <p>5 pegs for SA05/6/7</p>	
<p>2</p>	<p>3</p> <p>4 mm</p>

• **PLACEMENT ON THE HANDWHEEL**

<p>1</p>	<p>2</p>	<p>3</p>
----------	----------	----------

b. Fixed fingers adapters SUAxxx

Adapter	Maximum admissible torque (Nm)	Handwheel number of spokes	Handwheel type	Minimum handwheel \varnothing (mm)	Maximum handwheel center \varnothing (mm)	Assembly	
SUA001/901 placed on a Banjo head	2 fingers : 200	2, 4, 6, 8	Flat or moderately tapered (The angle between the spokes and the wheel plane doesn't exceed 30°)	184	108	Banjo head BJH (with or without rising stem) OR modec standard flange & shaft with the KPA004 interface (no rising stem)	
	3 fingers : 350	3 or 6		158	82		
	4 fingers : 1000	4		184	108		
	5 fingers : 1000	5		158	82		
SUA001/901 placed on a SUA002 drive plate	2 fingers : 200	2, 4, 6, 8		WITH or WITHOUT rising stem (maximum \varnothing : 100 mm)	184		217
	3 fingers : 350	3, 6			188		217
	4 fingers 2 spokes \rightarrow 200 \geq 4 spokes \rightarrow 1000	2, 4, 8			184		187
	5 fingers : 1000	5			263		187
	6 fingers 3 spokes : 350 6 spokes \rightarrow 1000	3, 6	293		217		
	7 fingers : 1000	7	293		217		
SUA034	3 fingers : 150	3, 6	Flat or moderately tapered with or w/o rising stem (max \varnothing : 54 mm)	88.5	61.5		
	4 fingers : 150	2, 4		88.5	61.5		

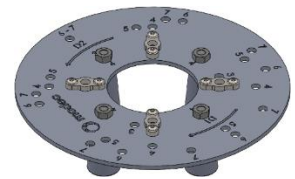
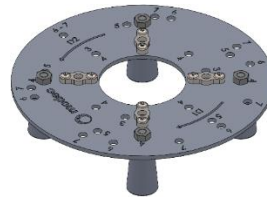
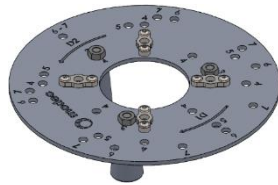
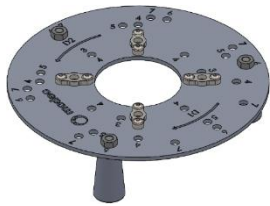

SUA003 = 3 x SUA001 placed on a SUA002 (large diameter)

(small diameter)

SUA004 = 4 x SUA001 placed on a SUA002 (large diameter)

(small diameter)

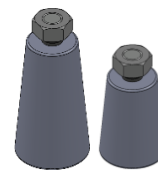
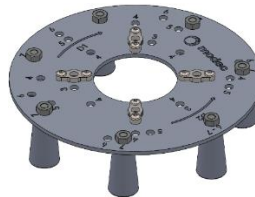

SUA005 = 5 x SUA001
Placed on a SUA002

SUA006 = 6 x SUA001
Placed on a SUA002

SUA007 = 7 x SUA001
Placed on a SUA002

SUA001 (65 mm)
SUA901 (45 mm)



SUA034 with 3 fingers

SUA034 with 4 fingers

SUA801 (45 mm) finger for SUA034

• SUA001/SUA901 ASSEMBLY ON A BANJO HEAD

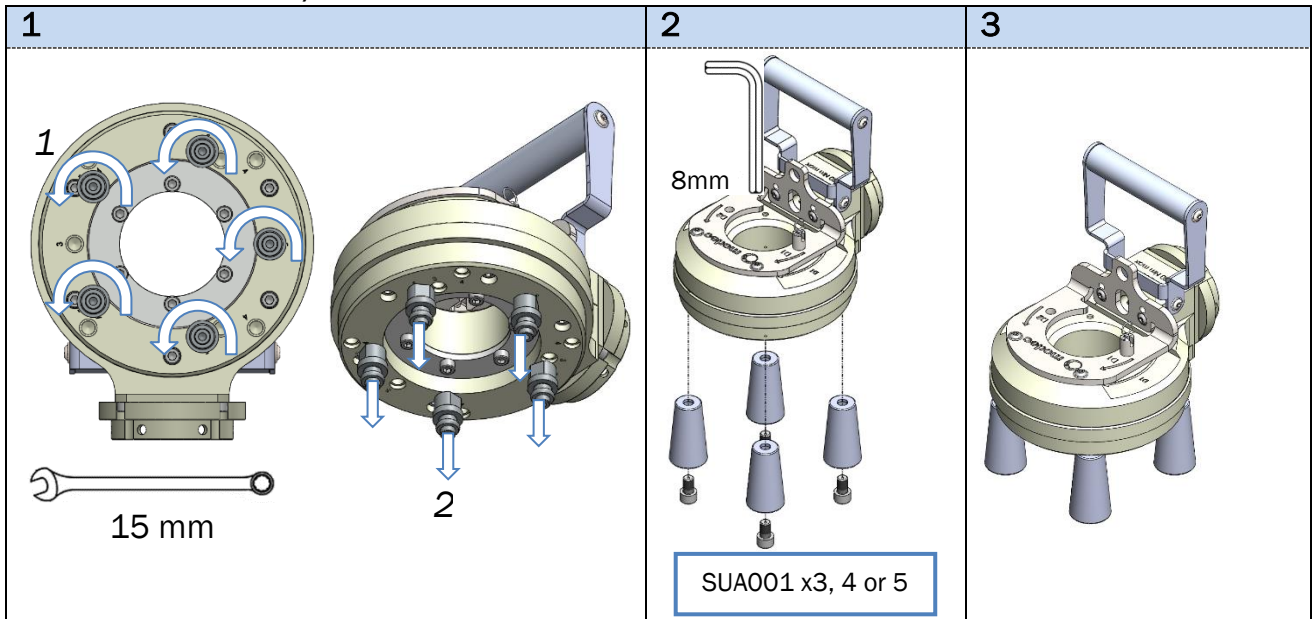

• SUA003/4/5/6/7 ASSEMBLY ON A BANJO HEAD

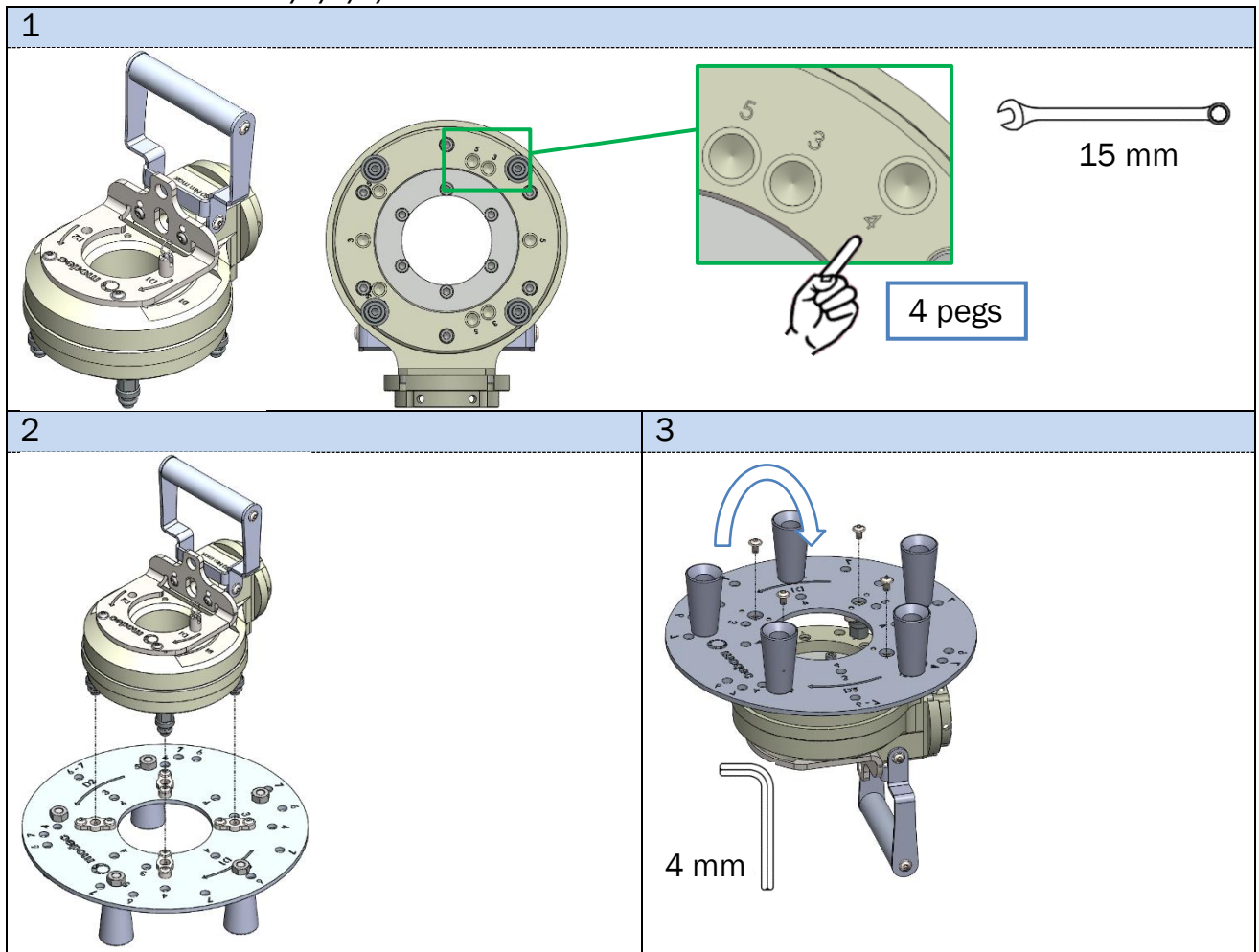

• SUA003/4/5/6/7 ASSEMBLY ON A **modec** STANDARD FLANGE & SHAFT

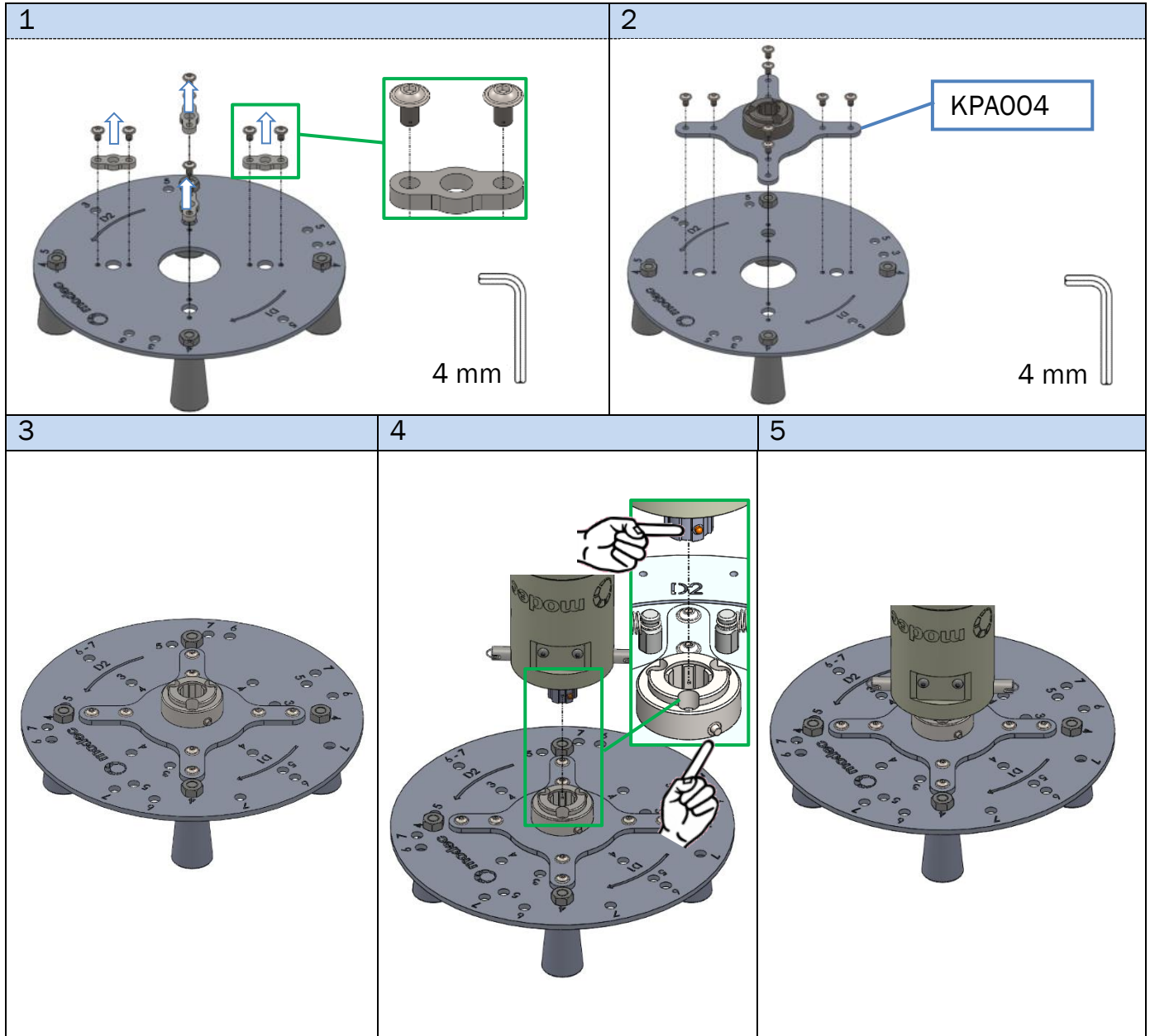

• **PLACEMENT ON THE HANDWHEEL**

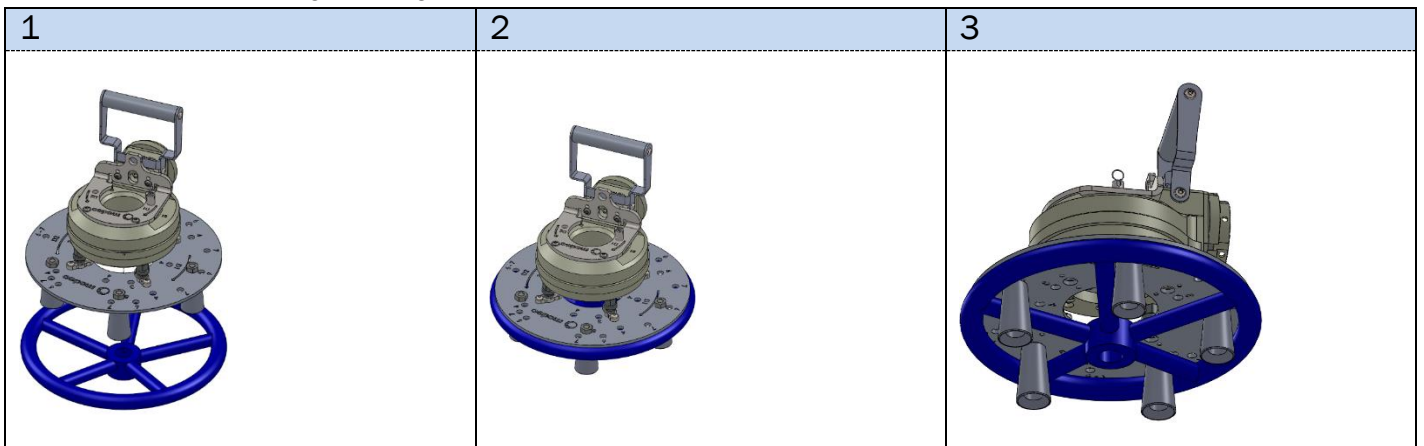

c. Spoke Adapters for flat handwheels FSBxxx

Adapter	Maximum admissible torque (Nm)	Handwheel number of spoke	Handwheel type	Extension bar inside Ø (mm)	Assembly
FSB245	1000	2 / 4 / 5	Flat or moderately tapered (The angle between the spokes and the wheel plane doesn't exceed 30°) WITH or WITHOUT rising stem	Ø50	Banjo head BJH (with or without rising stem) with TTA002 interface OR modec standard flange & shaft with the KTA002 interface (no rising stem)
FSB356	1000	3 / 5 / 6			

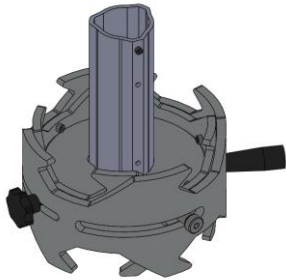

FSB245

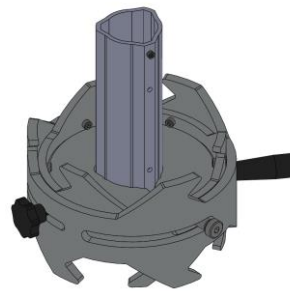

FSB356

• ASSEMBLY ON A BANJO HEAD

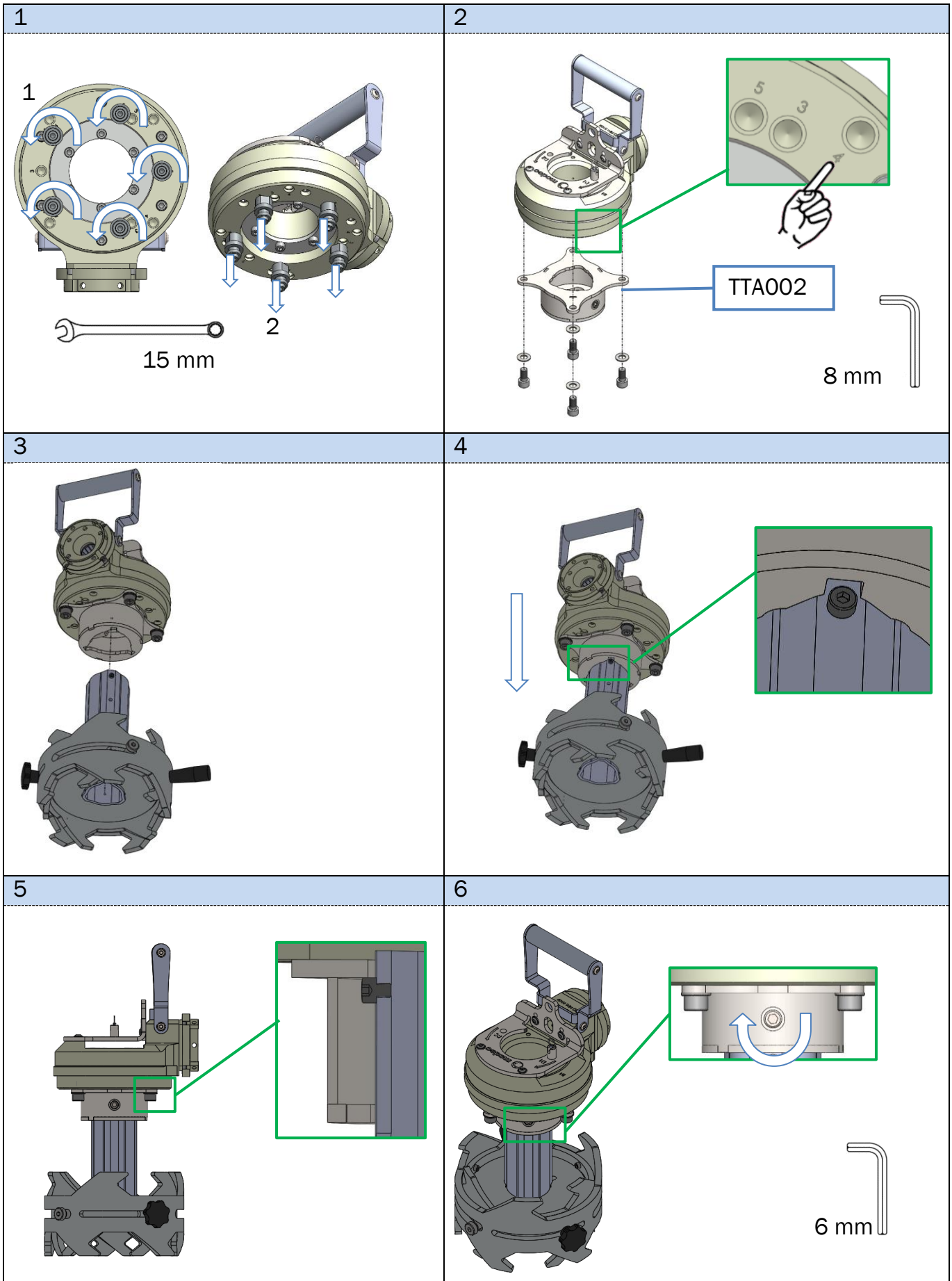

• ASSEMBLY ON A **modec** STANDARD FLANGE & SHAFT

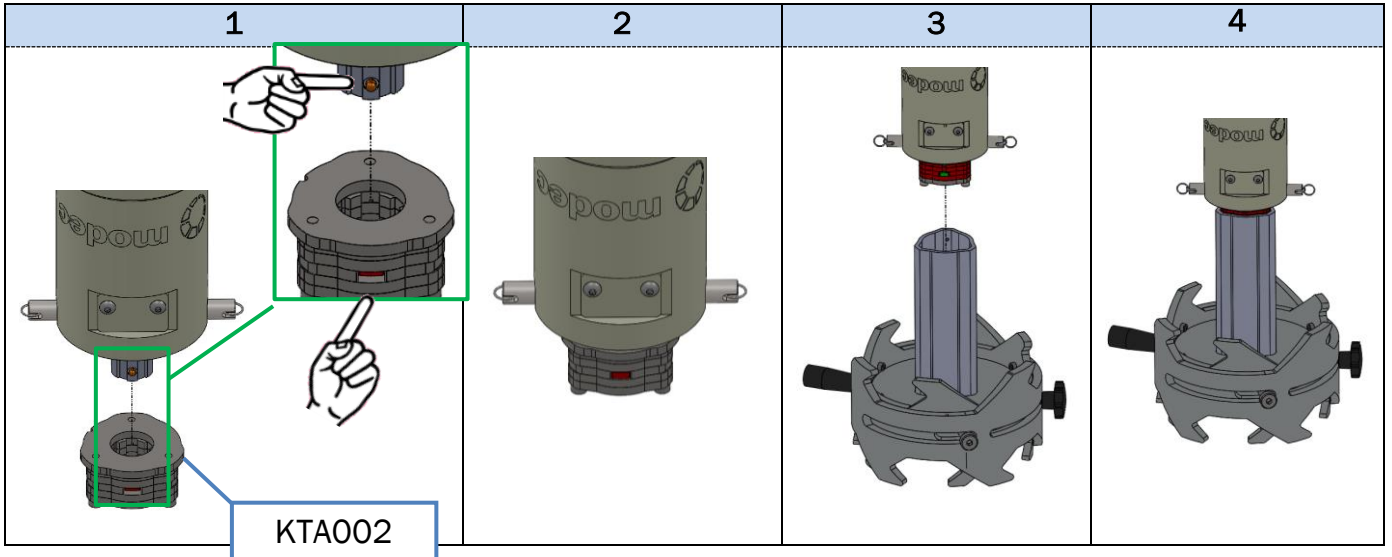

• PLACEMENT ON THE HANDWHEEL

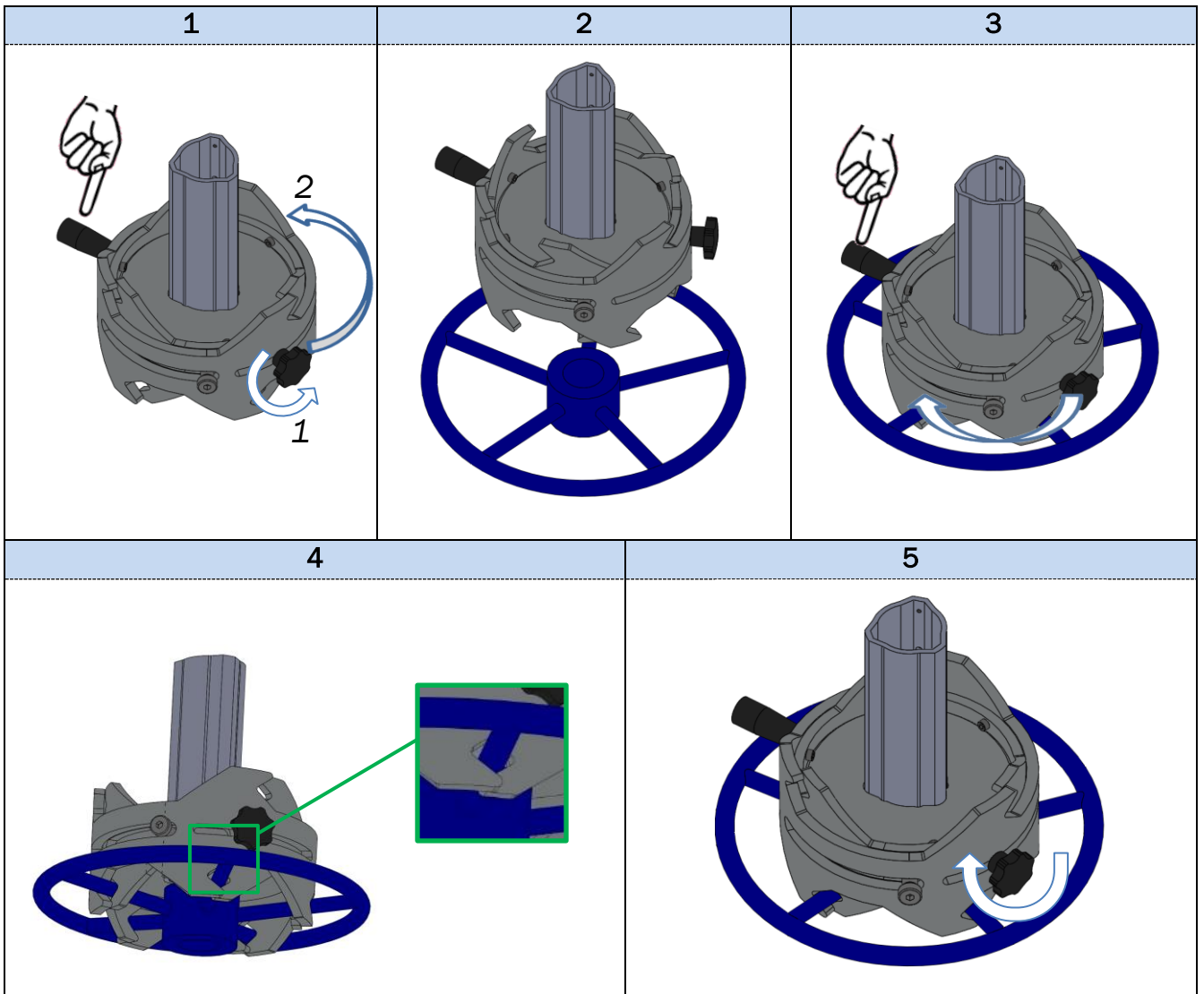

• CHANGING THE SIDE OF THE FSB

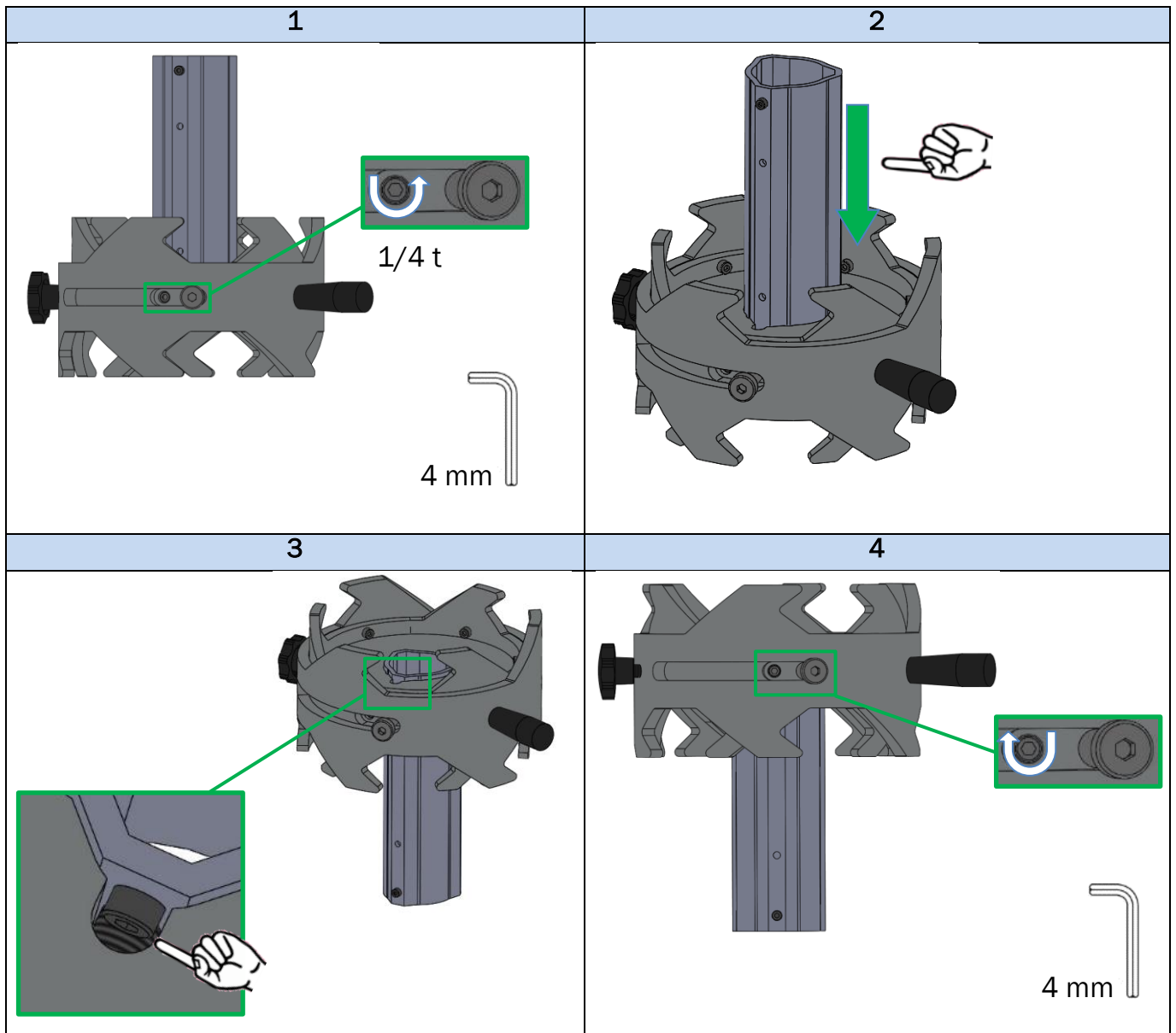

d. Spoke adapters for tapered handwheels CSBxxx

Adapter	Maximum admissible torque (Nm)	Handwheel number of spoke	Handwheel type	Extension bar inside Ø (mm)	Assembly
CSB003	1000	3 or 6	Tapered (The angle between the spokes and the wheel plane exceeds 30°) WITH or WITHOUT rising stem	Ø50	Banjo head BJH (with or without rising stem) with TTA002 interface OR modec standard flange & shaft with the KTA002 interface (no rising stem)
CSB004	1000	2 or 4			
CSB005	1000	5			

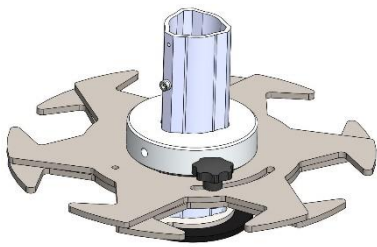

CSB003

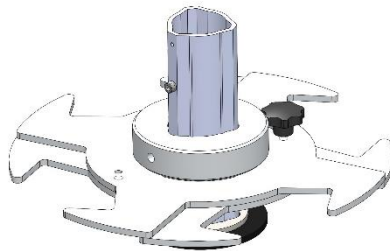

CSB004

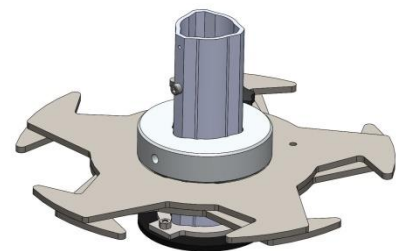

CSB005

• ASSEMBLY ON A BANJO HEAD

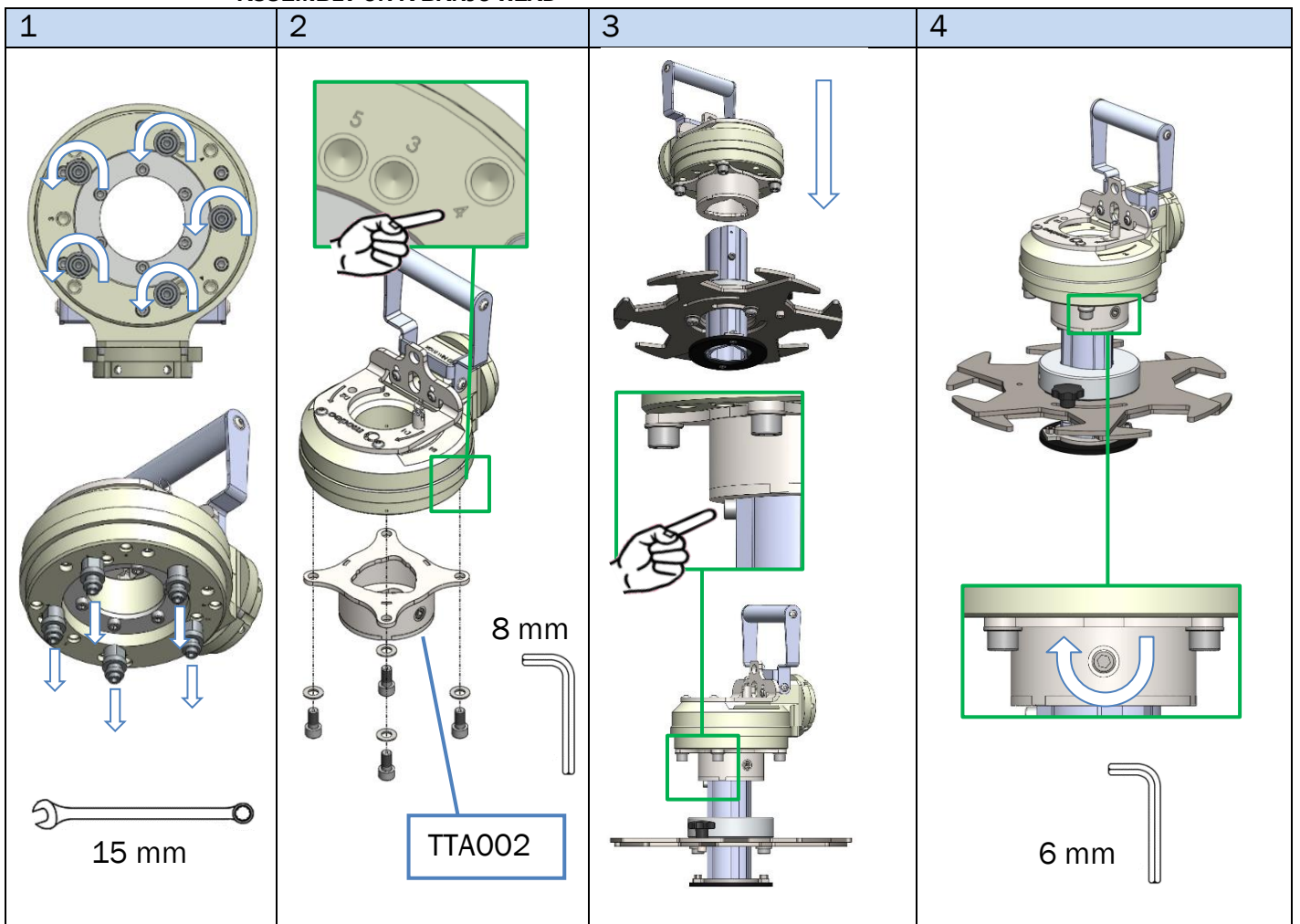

• ASSEMBLY ON A **modec** STANDARD FLANGE & SHAFT

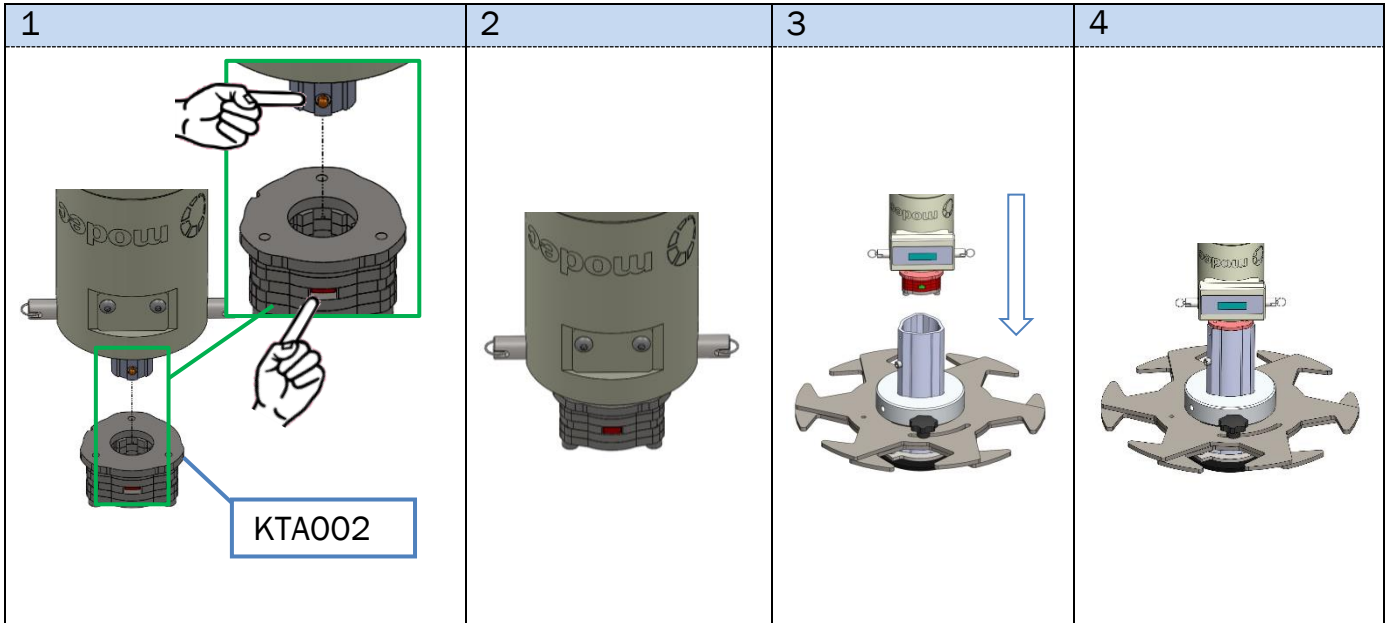

• PLACEMENT ON THE HANDWHEEL

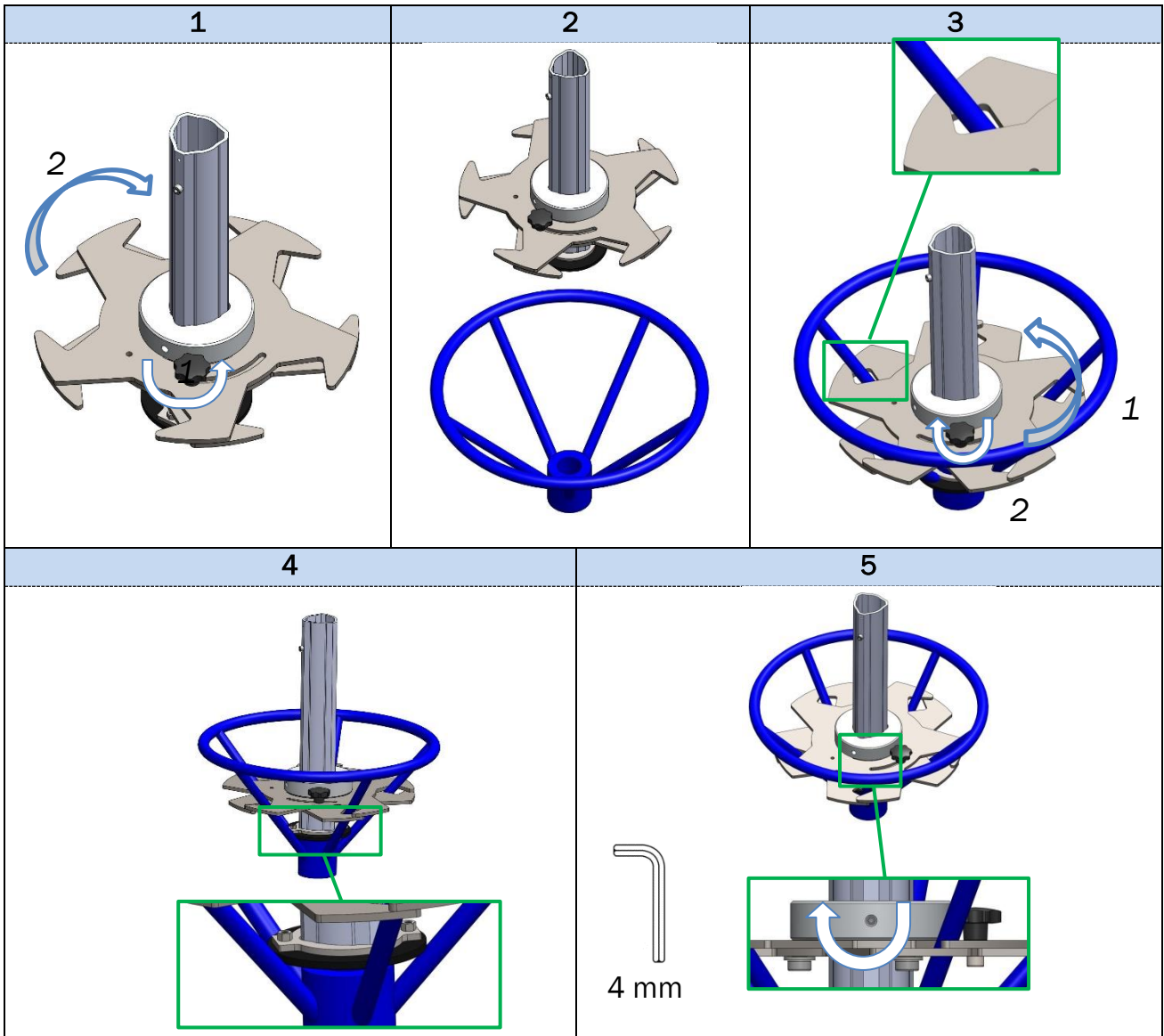

e. Fixed universal adapters FUAxxx

Adapter	Maximum admissible torque (Nm)	Handwheel number of spoke	Handwheel type	Assembly
FUA001	1000	2 to 6	Flat or moderately tapered (The angle between the spokes and the wheel plane doesn't exceed 30°) With or without rising stem	Banjo head BJH (with or without extension bar) OR Standard modec flange & shaft (with or without extension bar)
FUA002	1000	2 to 6	Moderately tapered (angle between spokes and wheel plane is between 30° and 40°) With or without rising stem	



FUA001 (top & bottom views)



FUA002 (top & bottom views)

• **ASSEMBLY ON A BANJO HEAD WITHOUT EXTENSION BAR**

1

2

3

• ASSEMBLY ON A BANJO HEAD WITH EXTENSION BAR

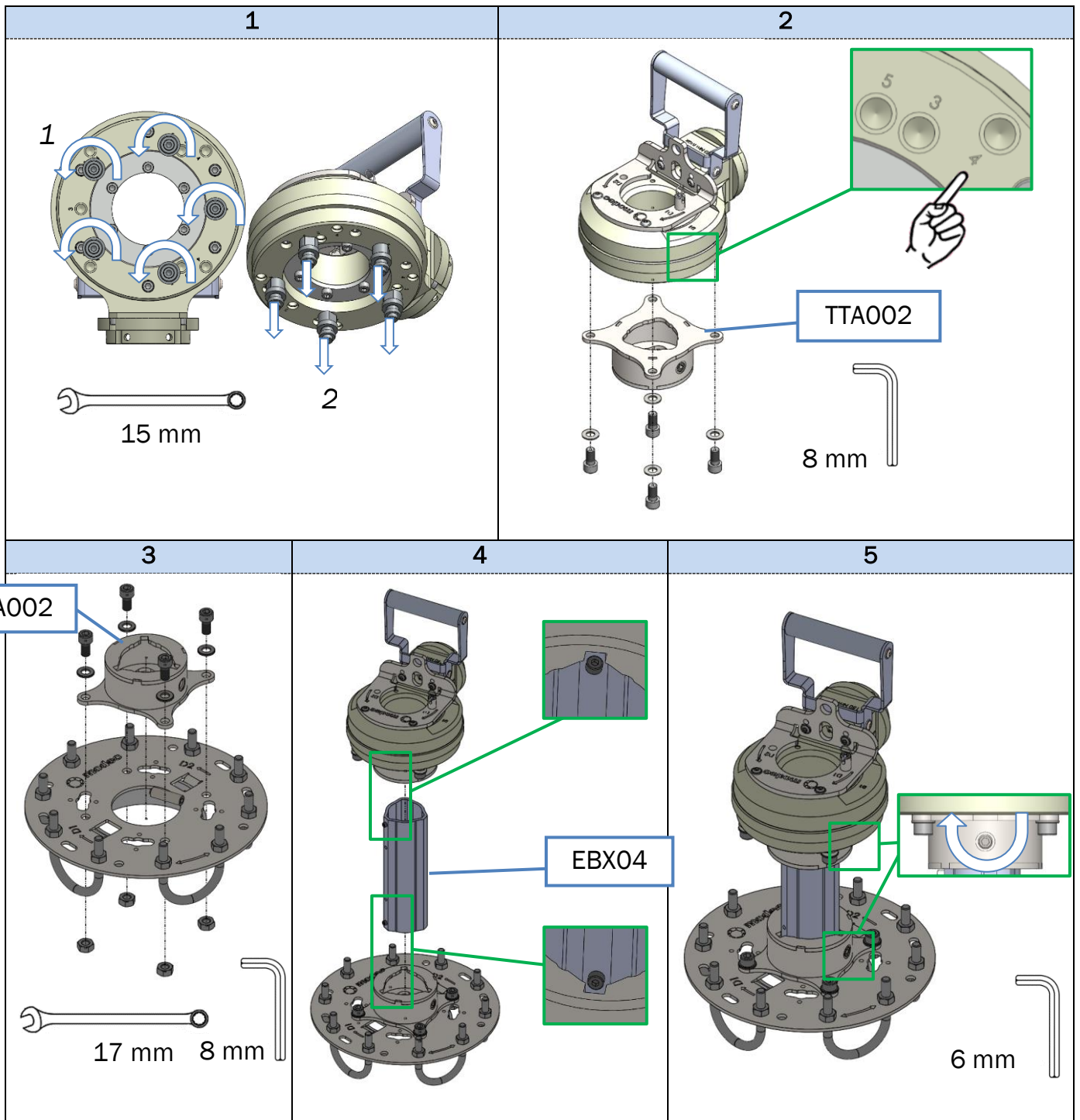

- **ASSEMBLY ON A modec STANDARD FLANGE & SHAFT WITHOUT EXTENSION BAR**

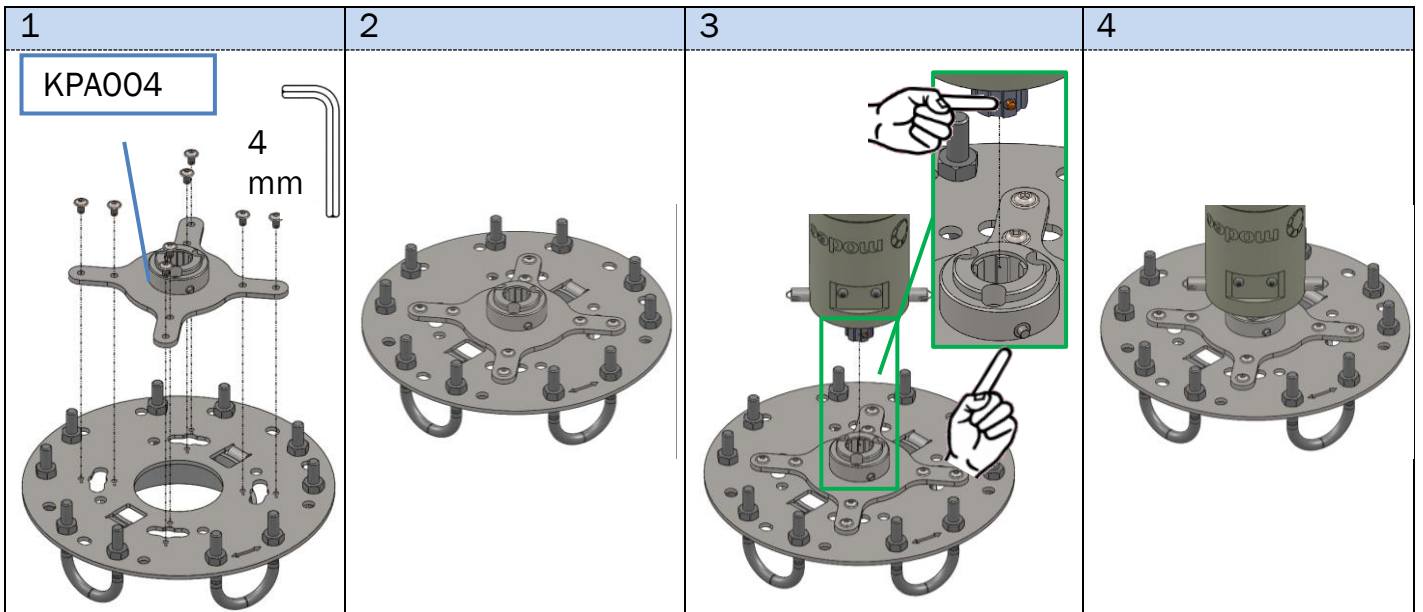

- **ASSEMBLY ON A modec STANDARD FLANGE & SHAFT WITH EXTENSION BAR**

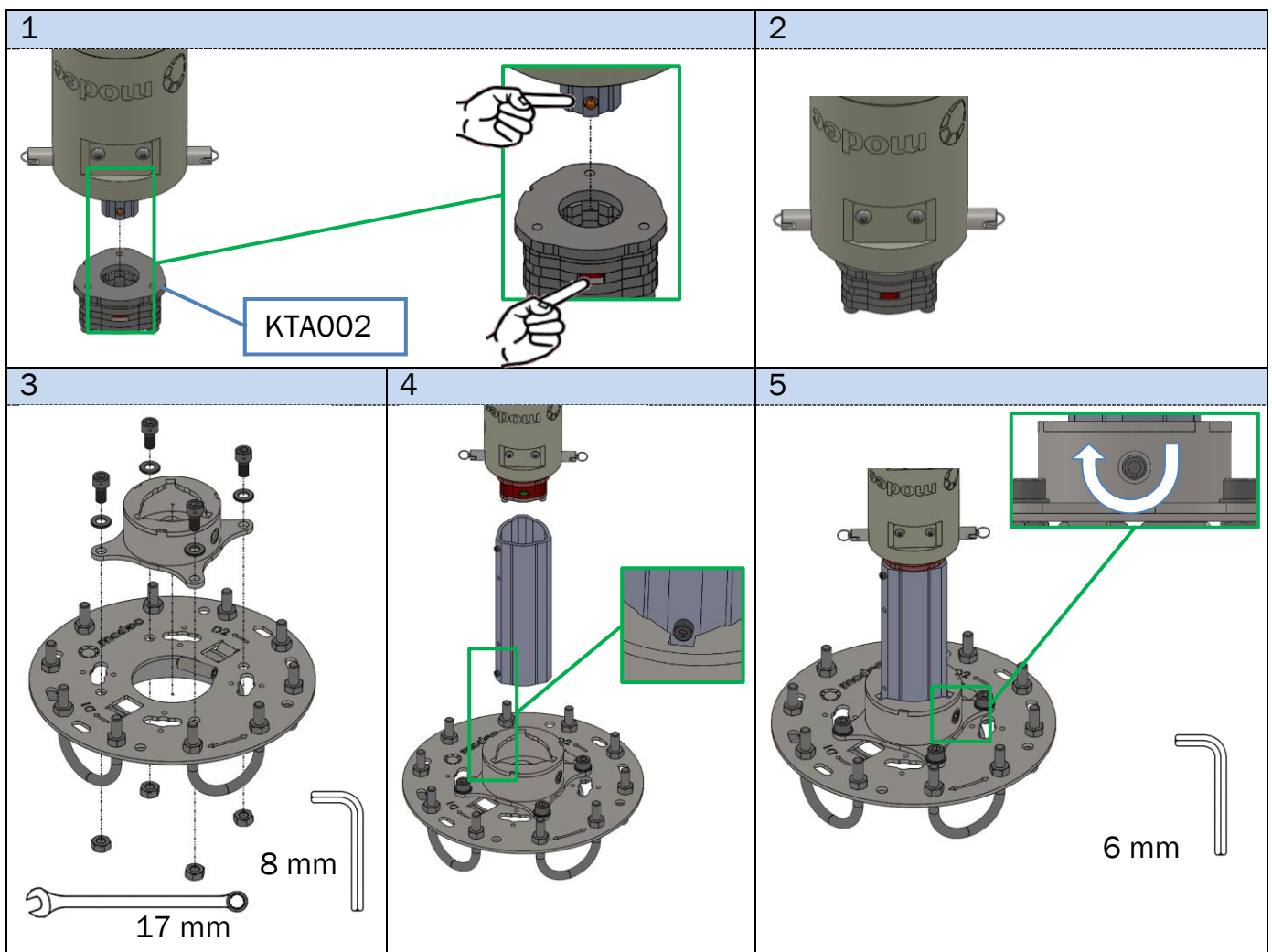

• **PLACEMENT ON A HANDWHEEL**

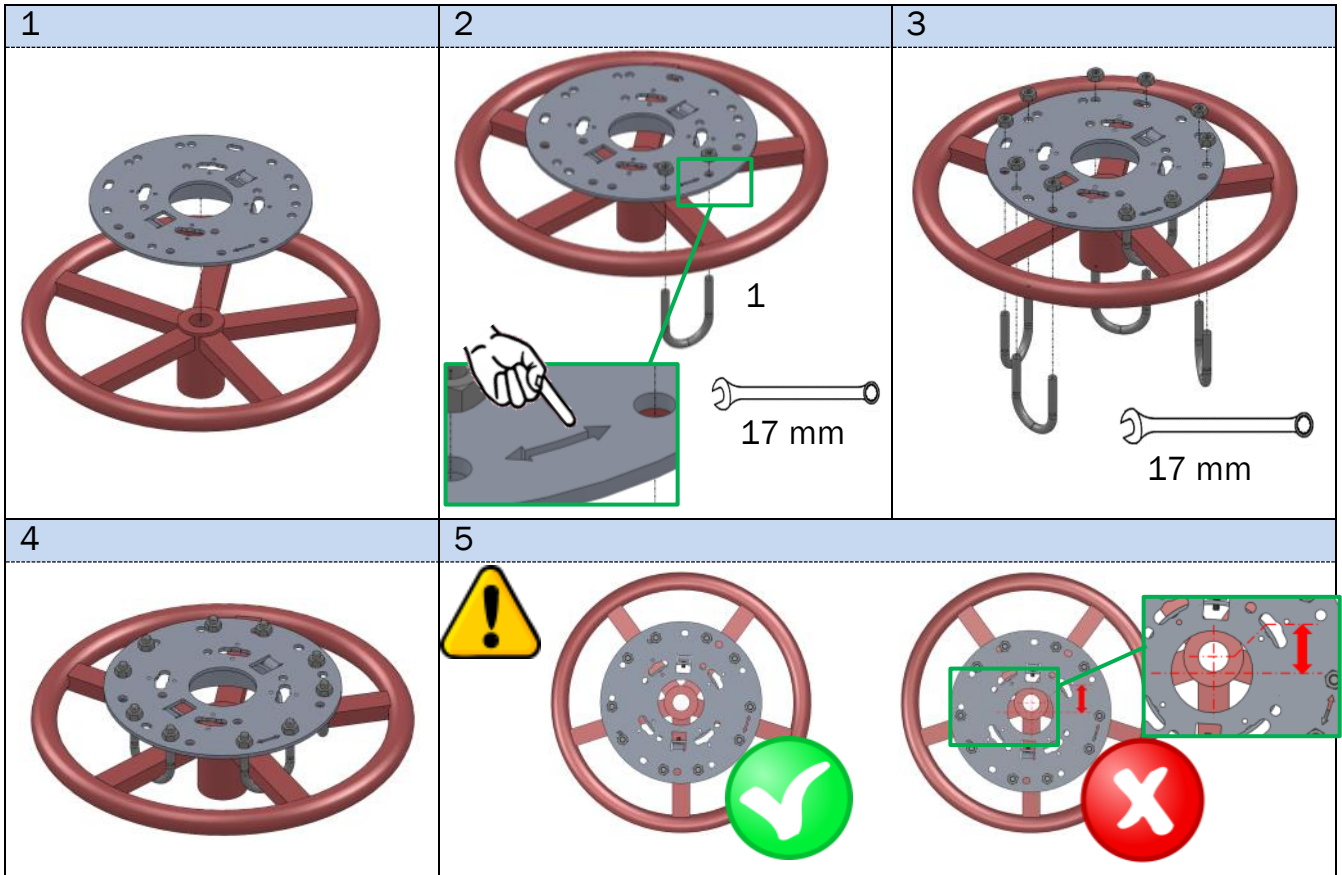

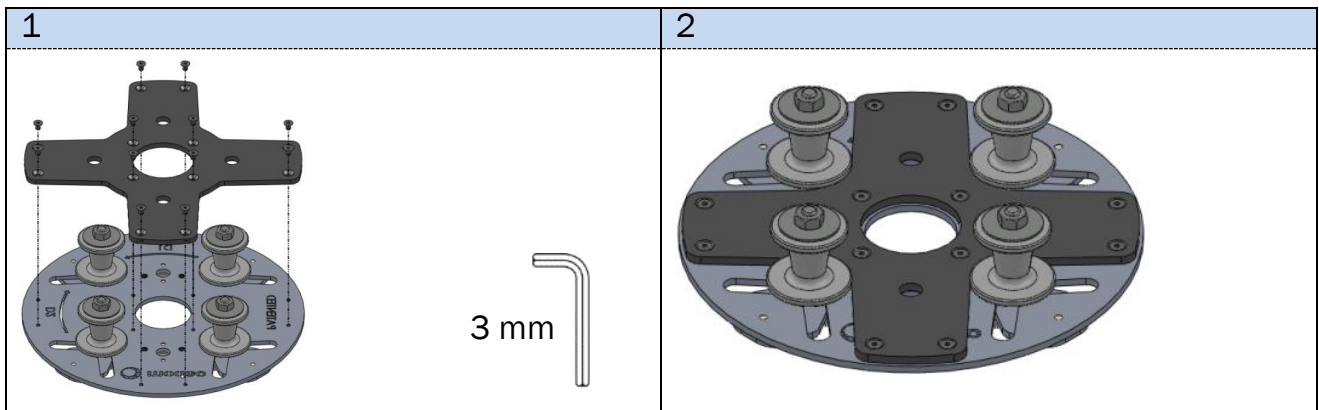
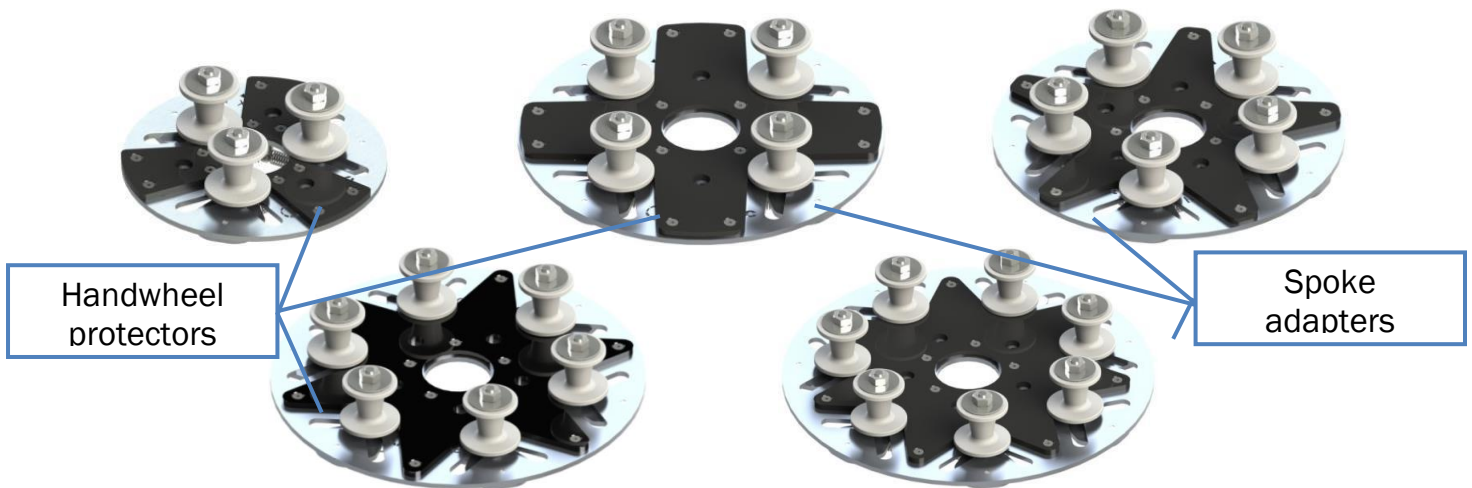

9. Accessories

a. Handwheel protectors for use with SAxxx adapters



b. Square drives

These 3/4" can be used with any standard socket so that you can use your actuator to rotate any screw or bolt. By removing the male 3/4" shaft, you get a female 3/4" drive.

Interface	Maximum admissible torque (Nm)	Assembly	Picture
TTA3/4	1000	Banjo head BJH	
KTA3/4	1000	Standard modec flange & shaft	

- TTA3/4 ASSEMBLY ON A BANJO HEAD

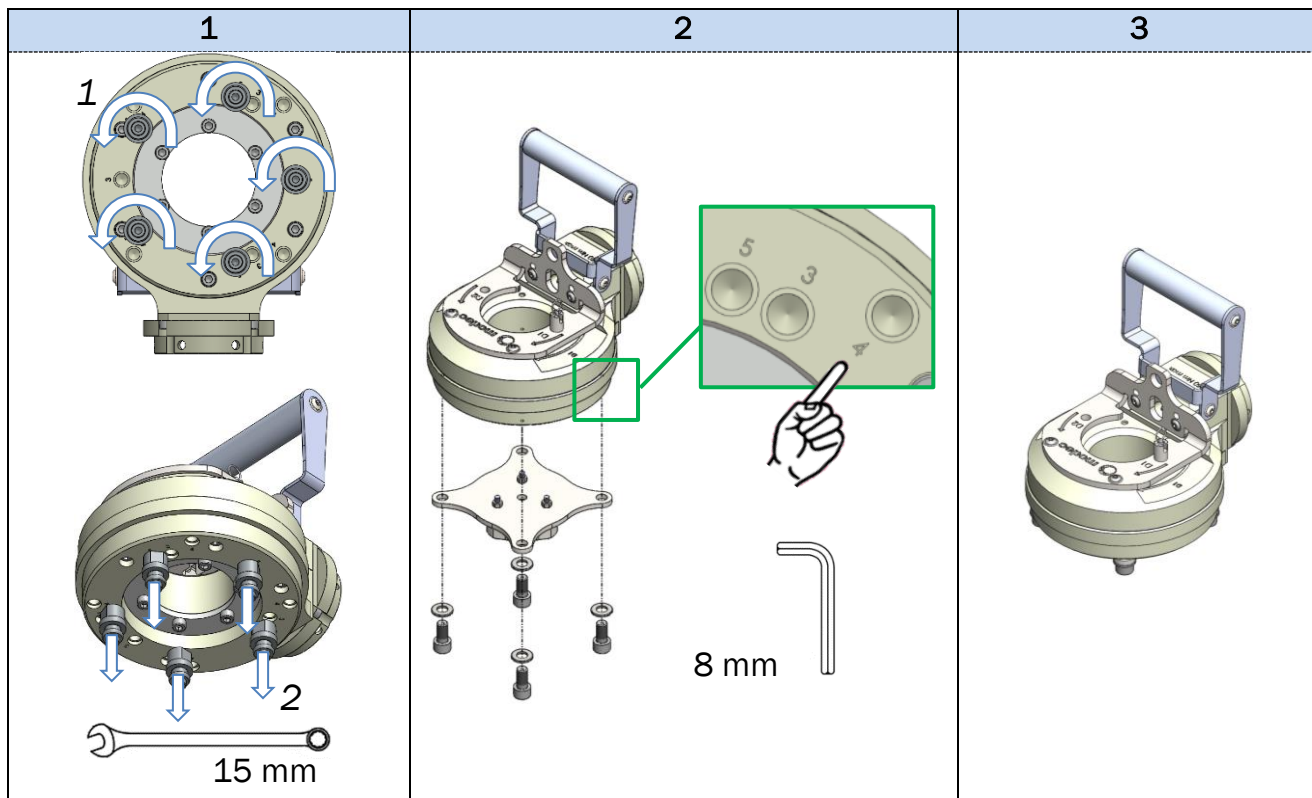

- TTA3/4 ASSEMBLY ON STANDARD **MODEC** FLANGE & SHAFT

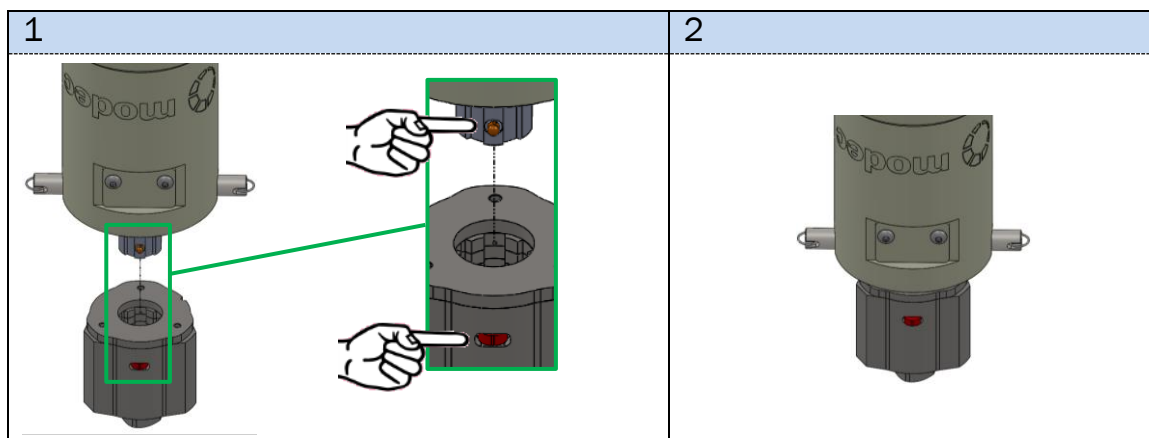

• HOW TO INSTAL AND REMOVE THE 3/4 SQUARE DRIVE

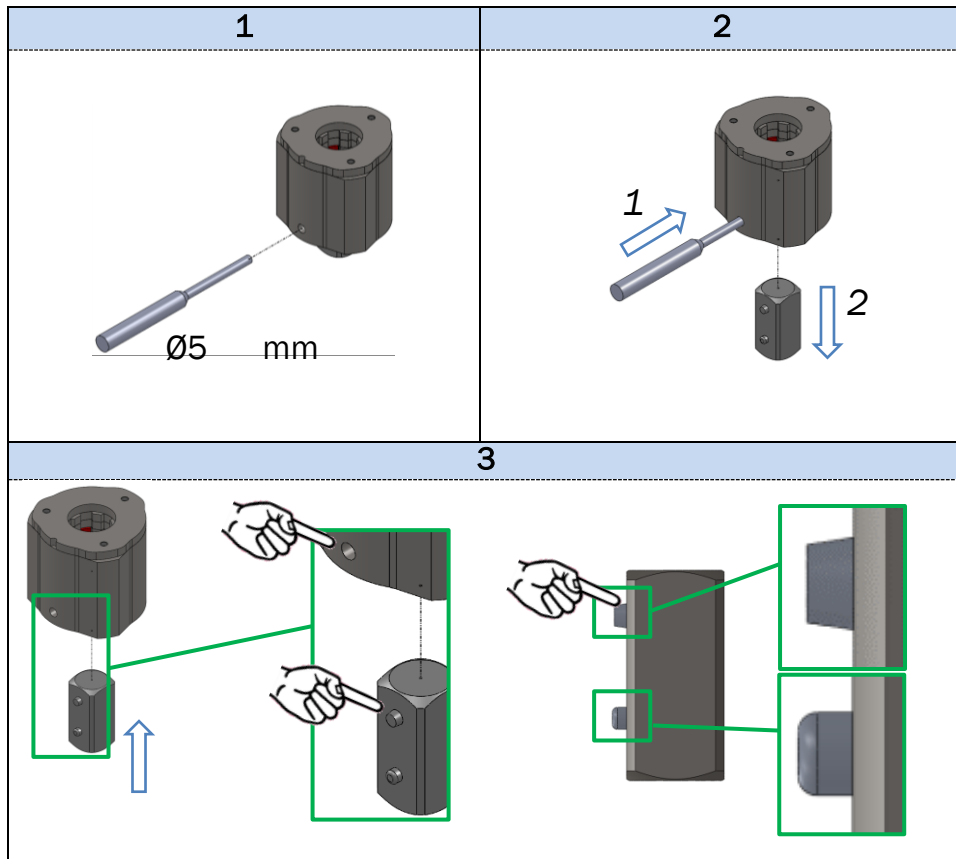

c. Telescopic valve key

The telescopic valve keys (EB001/EB002) allow actuating underground buried valves. They are equipped with a 3/4" square drive at one end so that they can be use with any socket and accept the actuator or right angle head (RA30) splined shaft on the other end. Their length varies from 1m to 1,7m with 10cm steps for the EB001 and from 0.6m to 0.9m with 7.5cm steps for the EB002.

Maximum acceptable torque : 1000 Nm

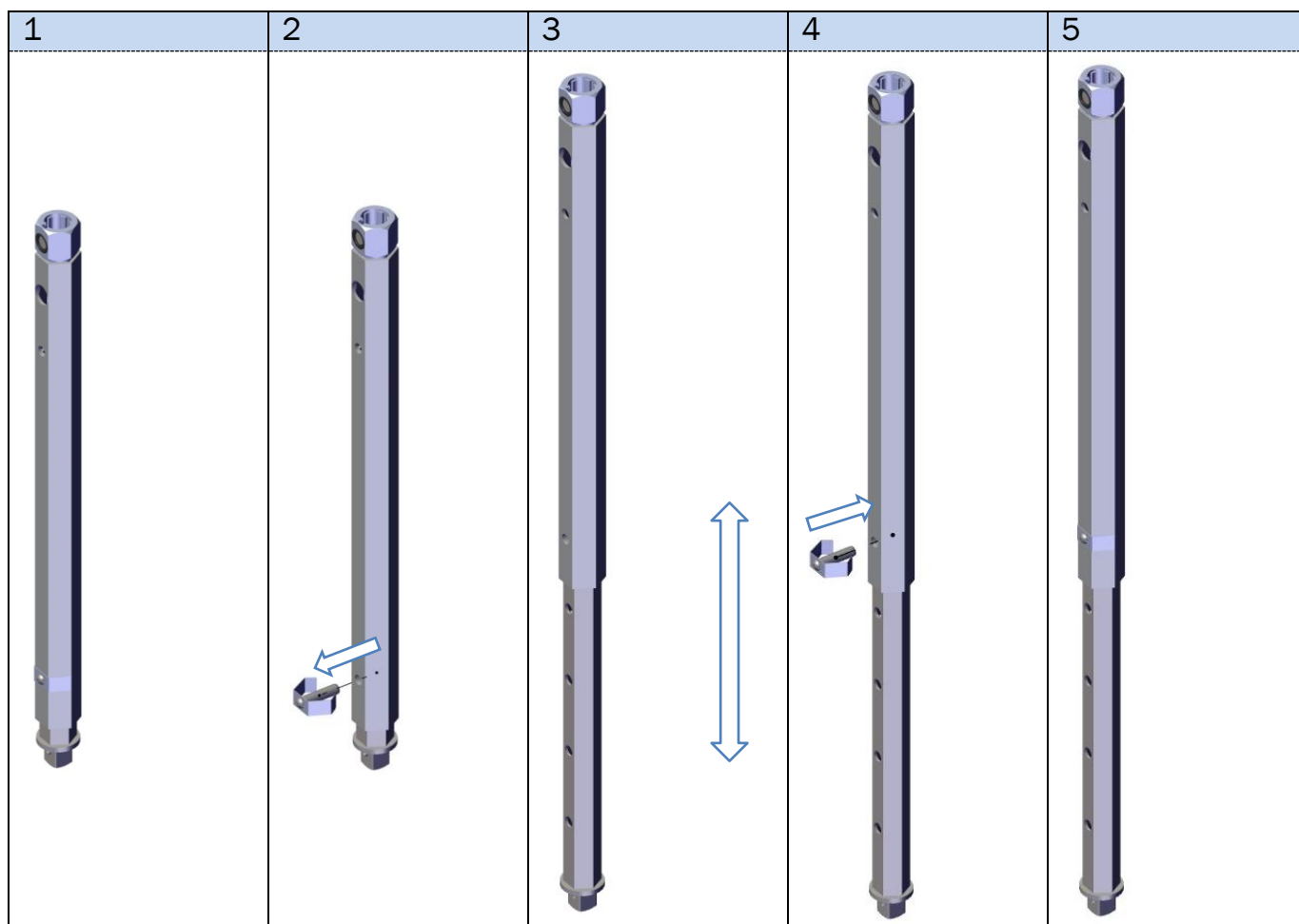

d. Interface for use of the telescopic valve key with a BJH

This interface makes the use of the telescopic valve keys (EB001 / EB002) possible with a banjo head (BJH01, BJH02).



Reference : KHA002

Maximum acceptable torque : 1000 Nm

- EB001/002 CONNECTION TO A **MODEC** STANDARD FLANGE & SHAFT

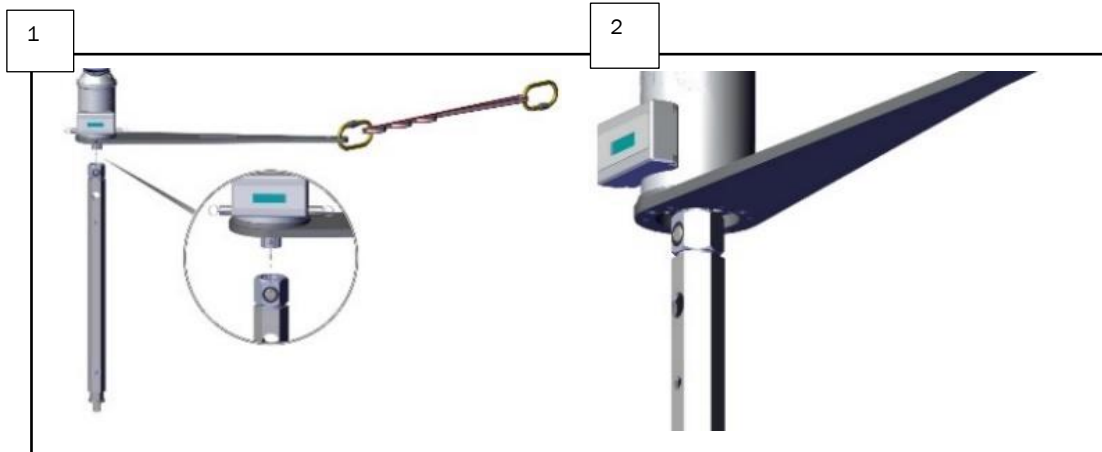

- KHA002 ASSEMBLY ON A BANJO HEAD AND CONNECTION TO A EB001/002

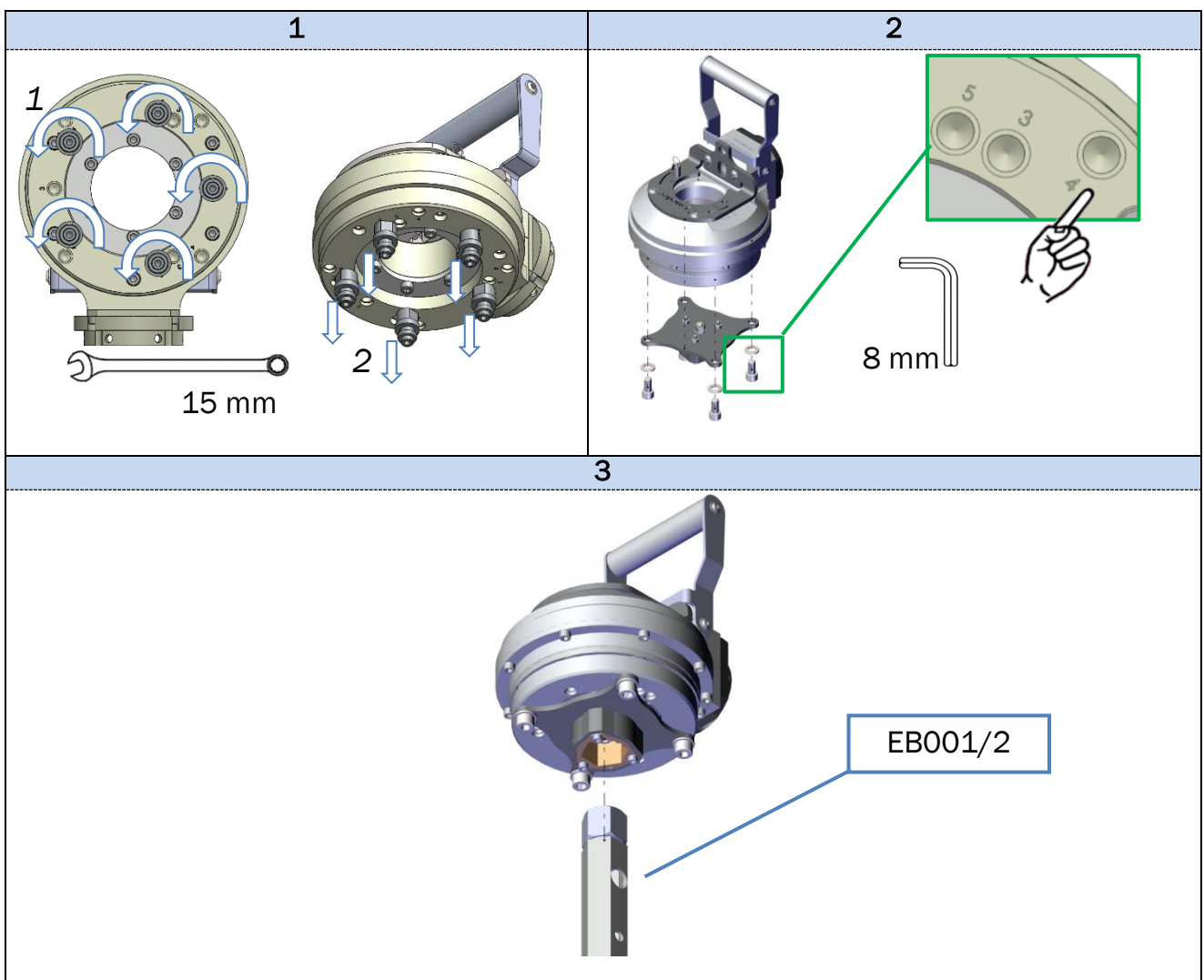

10. Torque management systems

a. Single reaction arm BR001

See Portable Valve Actuators' instruction notices

b. Double reaction arm BR002

Maximum admissible torque : 1000 Nm.

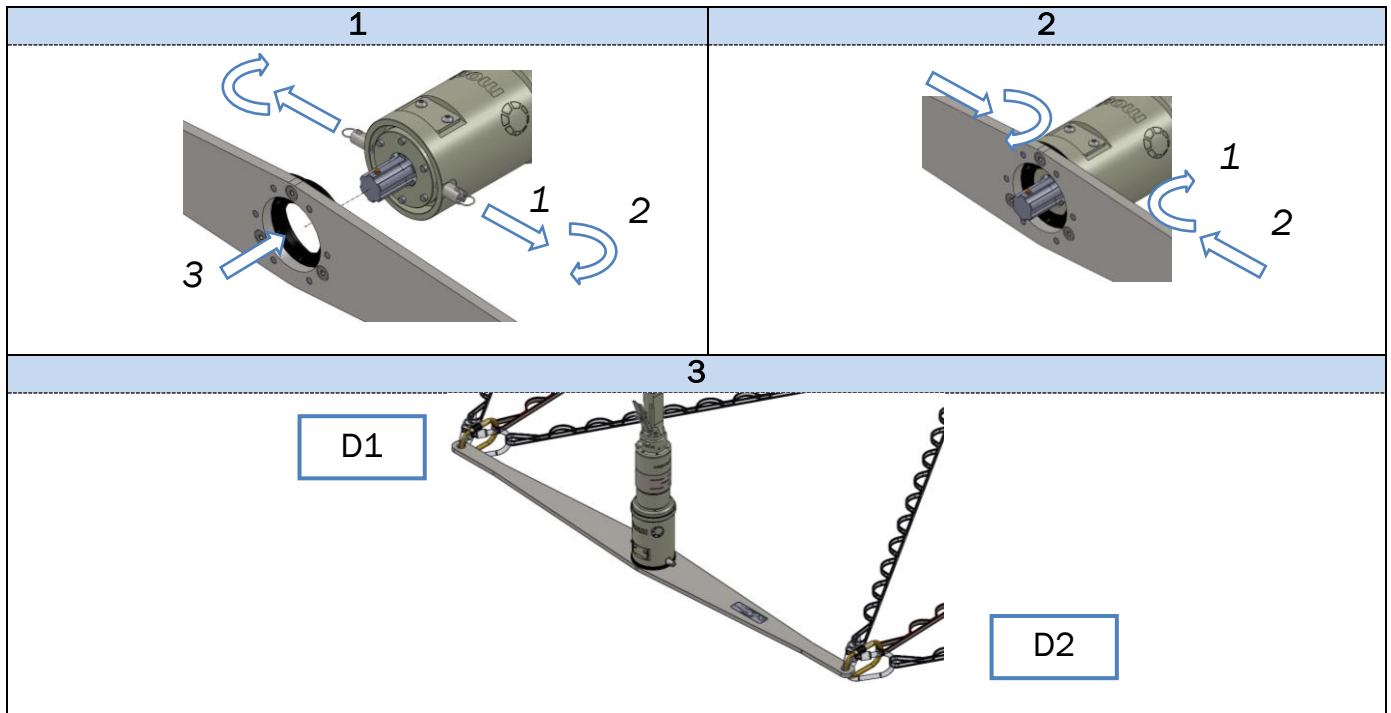

c. Reaction arm for Banjo head BR003

Maximum admissible torque : 1000 Nm. Assembly is identical for BJH01 and BJH02.

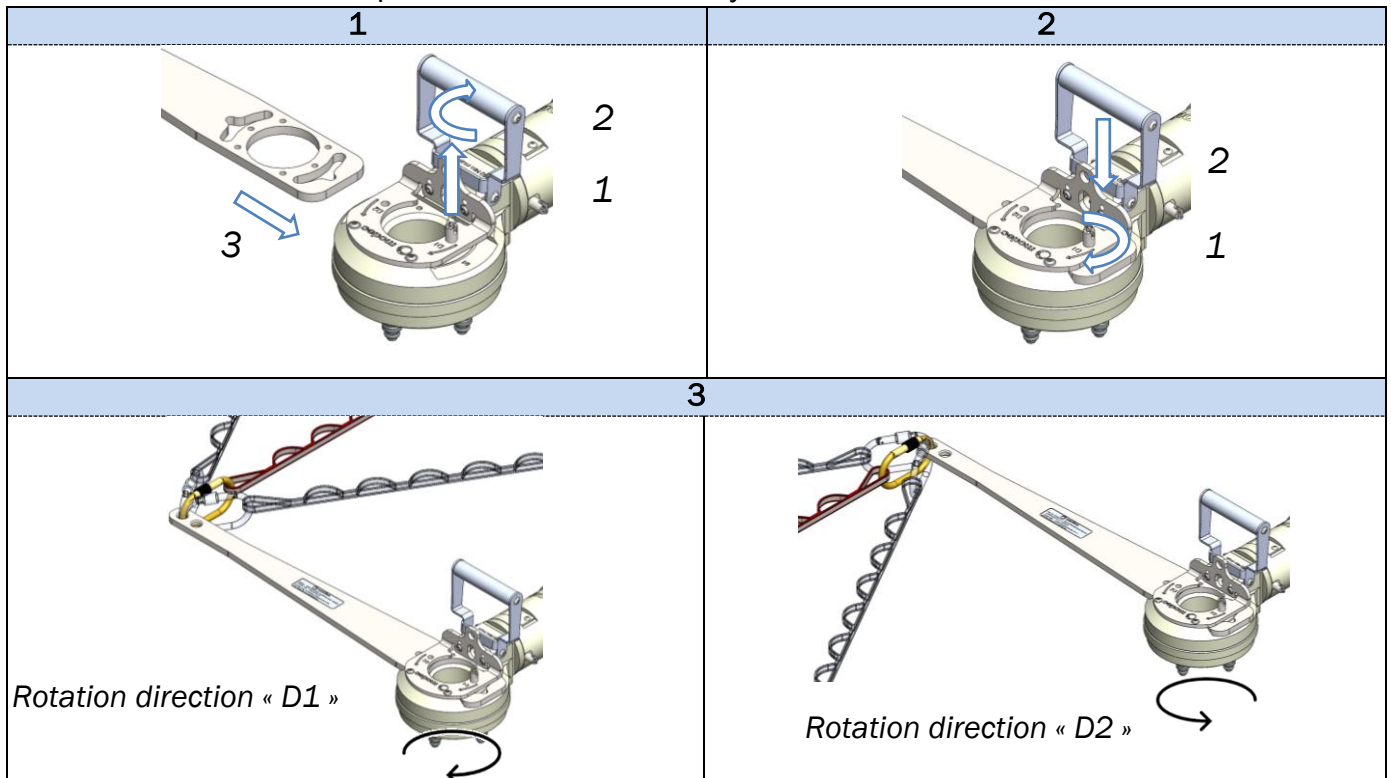

d. Articulated reaction arm fixed to vehicle trailer hatch BA001

Maximum admissible torque : 1000 Nm

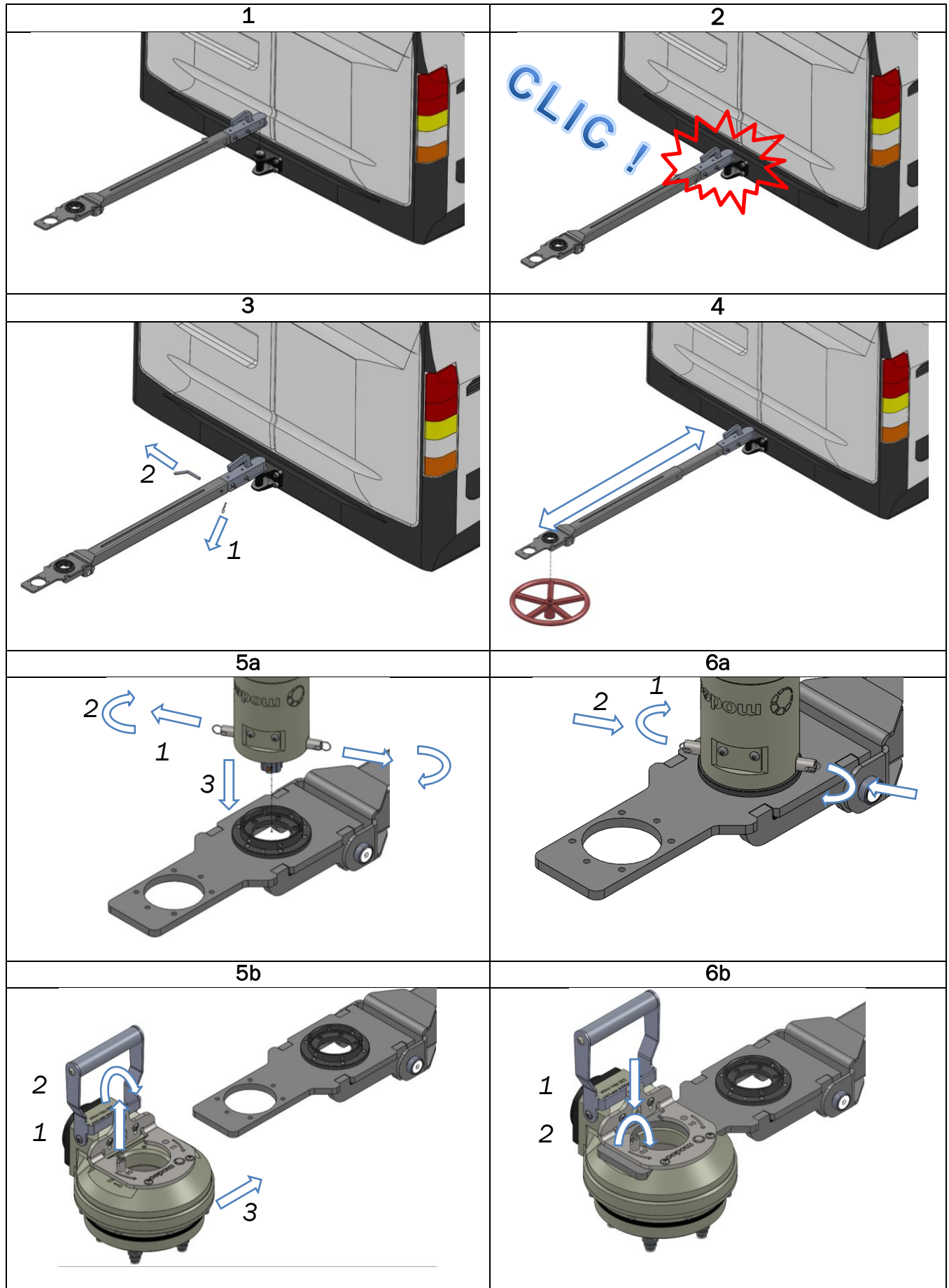

e. Foot held articulated reaction arm BA002

Maximum admissible torque : 350 Nm.

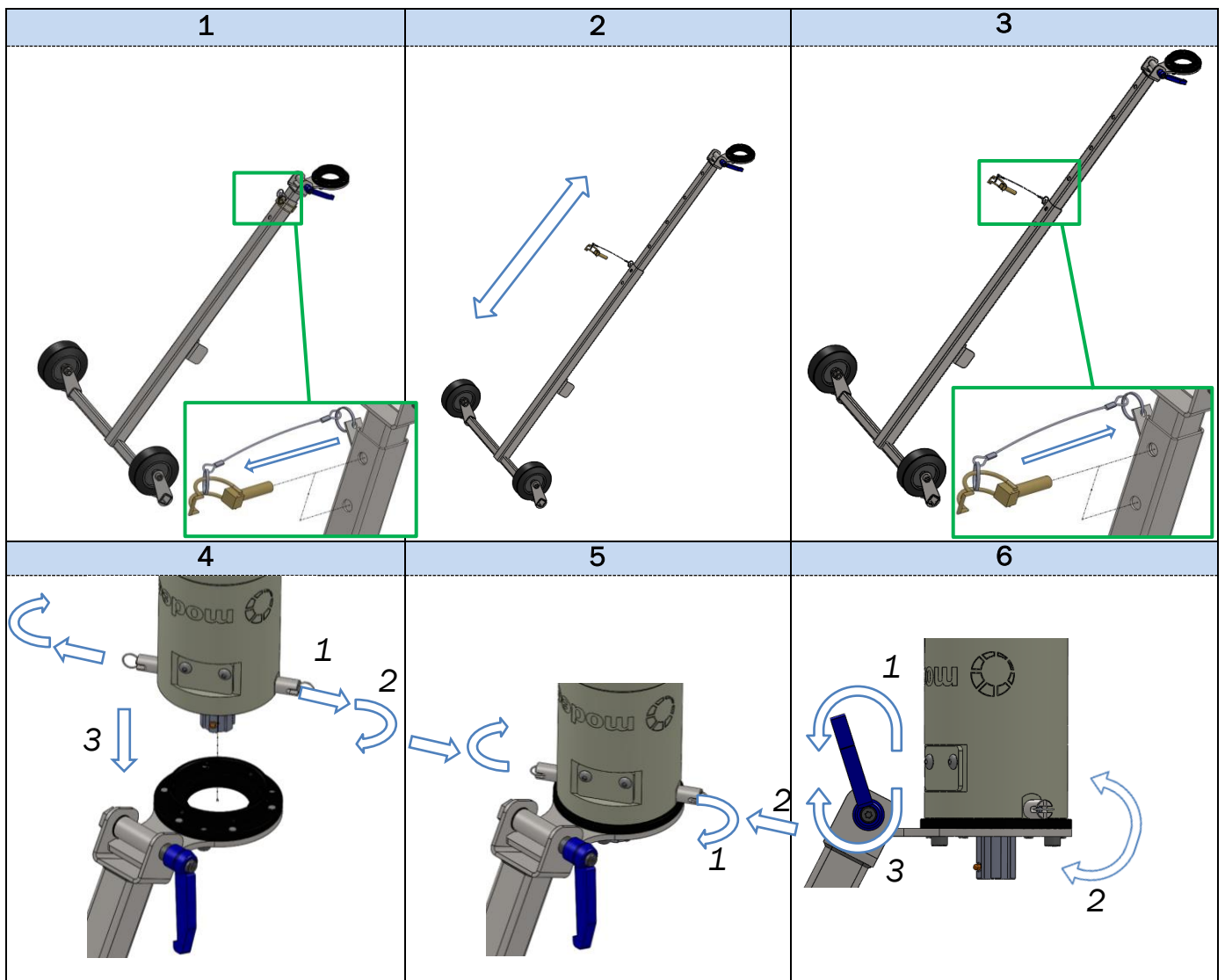
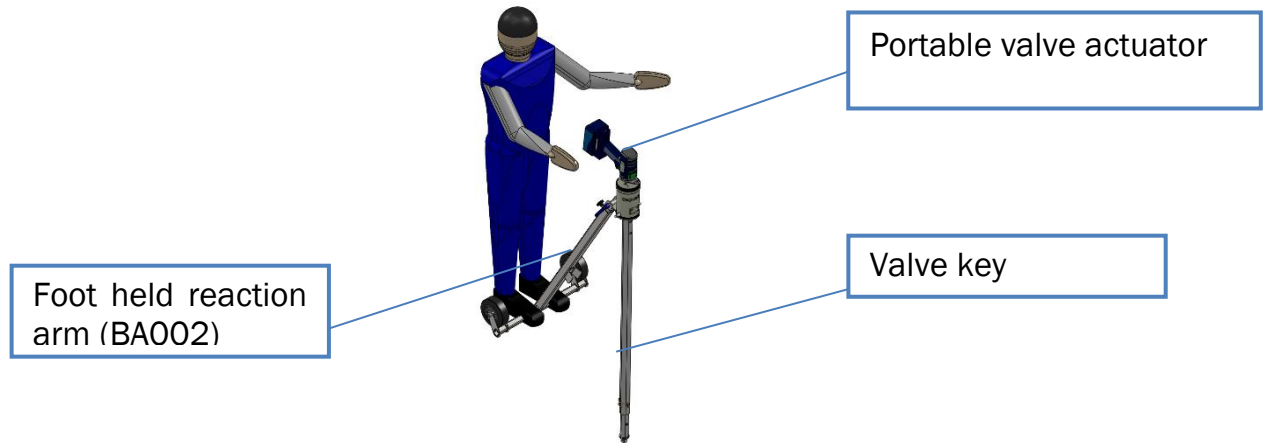

f. Stand for underground / buried valves SE001

Maximum admissible torque : 350 Nm.

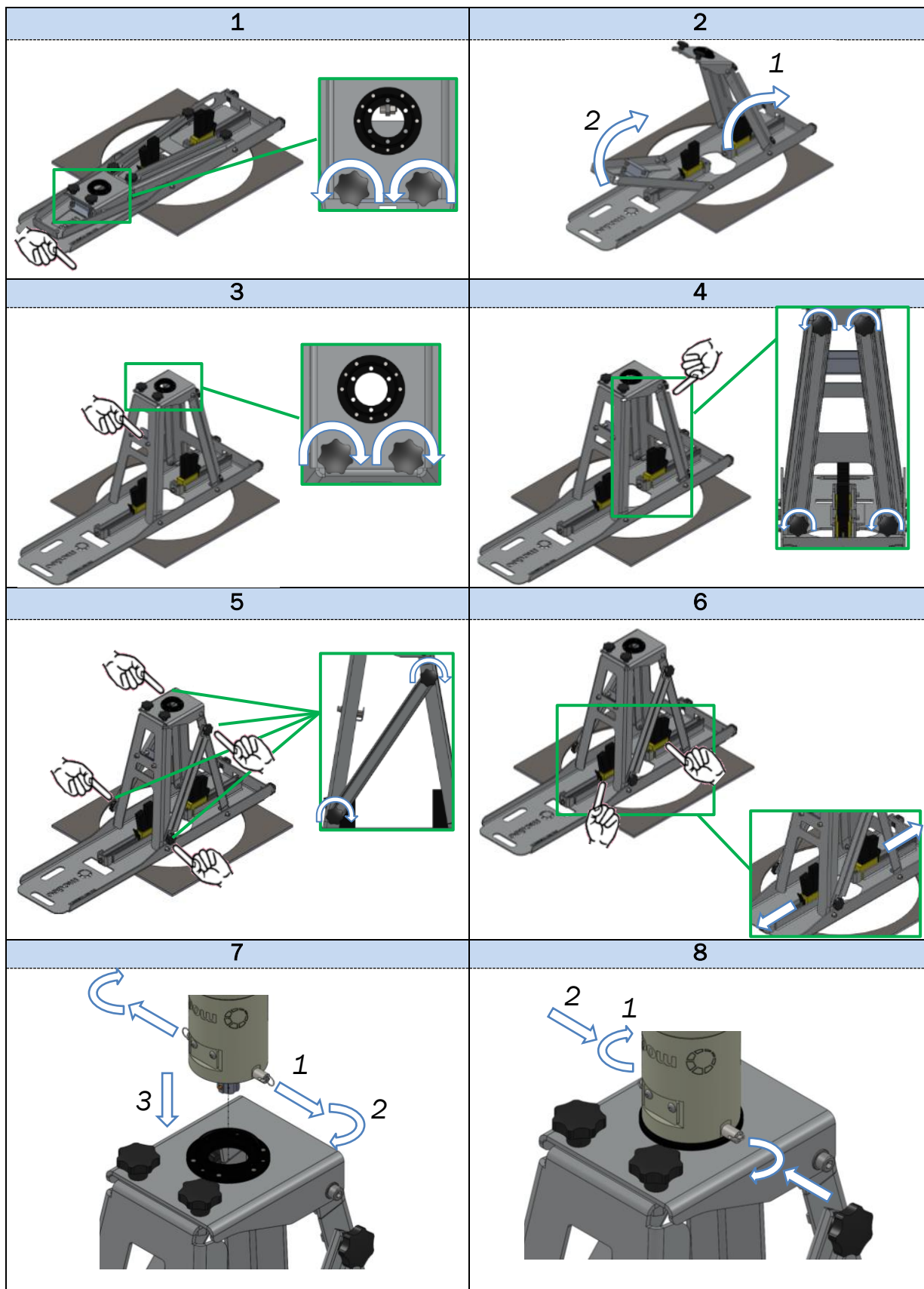

g. Telescopic bipod BP001

Maximum admissible torque : 350 Nm.

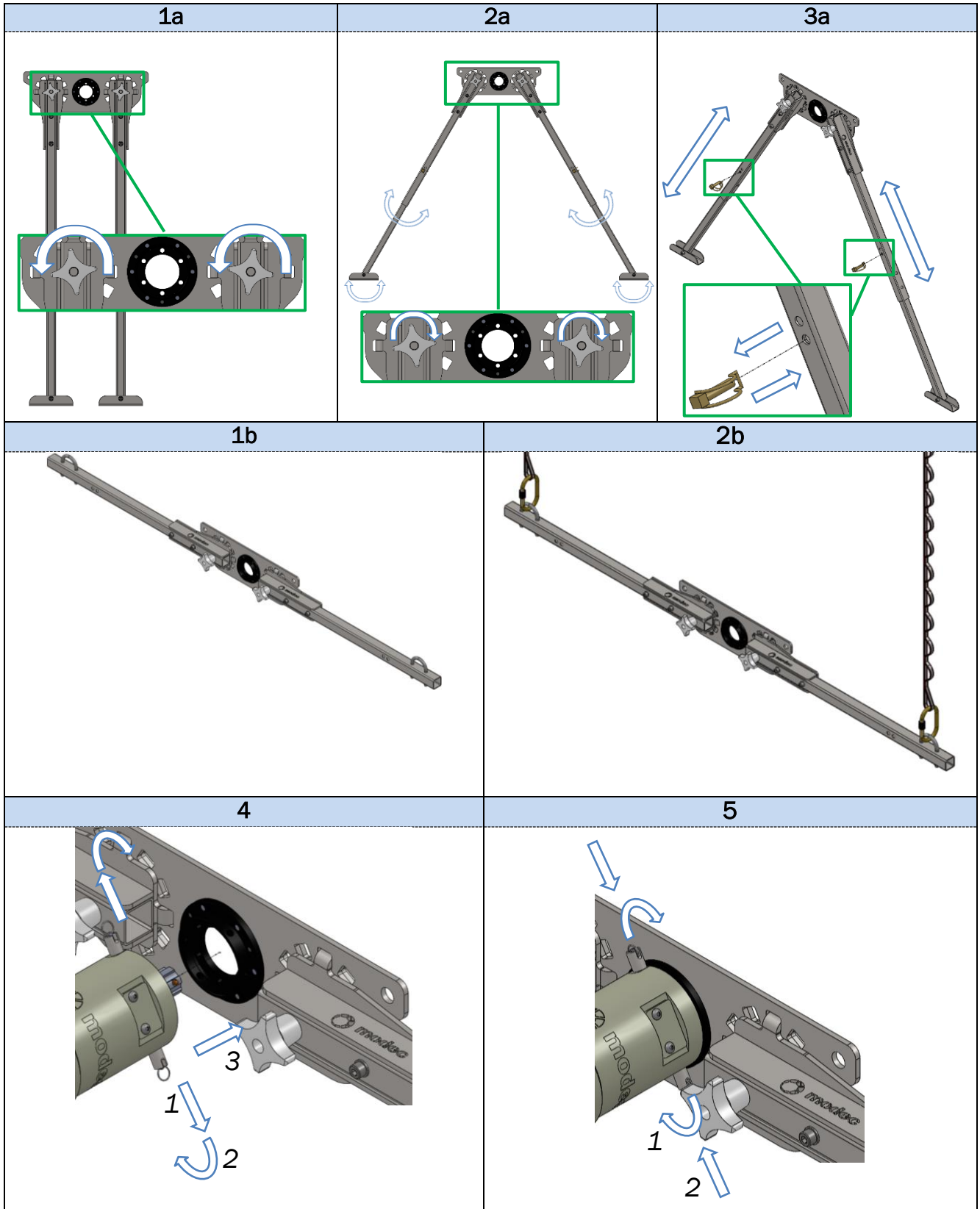

Warranty

modec guarantees its equipment in accordance with the following conditions:

- During 12 months as of the delivery date, **modec** warrants its equipment against all material and manufacturing defects, except for consumable parts and elements that are out of order due to normal wear and tear further to standard use 8 hours per business day. During the aforementioned period, **modec** will replace or repair all parts acknowledged as defective by our departments, which parts shall have been promptly returned by the buyer to **modec** plants, all carriage costs and duties paid, enclosing a detailed description of the recorded breakdown and the warranty certificate.
- Components that were not manufactured by us come under the relevant manufacturer's warranty.

This warranty shall only be applicable if the machine is used with **modec** consumables. We hold no liability if our products are used in an abnormal manner.

Agreement review

Significant modifications in the Buyer's economic or financial situation, including the sale, transfer, pledge or contribution of the latter's business or assets, and if payment or acceptance of bill is not performed on the agreed date, even further to partial order performance, may entail revision of the conditions thereof and the overall credit conditions granted.

Intellectual Property

We continue to hold all intellectual property rights to our projects, studies and documents that shall not be communicated, exploited or reproduced without our prior written authorization.

Force Majeure event

modec shall not be held responsible for any breach whatsoever of its contractual obligations that result from causes which are beyond our control such as, amongst others: fire, storms, flooding, earthquake, explosion, accident, strikes and/or industrial disputes, hostile actions, insurrection, war (declared or otherwise), rebellion, sabotage, epidemics, quarantine, impossibility of ensuring supplies of parts, raw materials or machinery, Government decision and legal actions.

Applicable law

The agreement shall be governed and construed in accordance with French law.

Power of Jurisdiction

All disputes or litigation which have not been amicably settled shall be referred to the Commercial Court of Romans, acknowledged as sole competent jurisdiction by the contractors, including in the event of the introduction of third parties.

Other conditions

Those of the Federation of Mechanical Industrialists of France.



modéc



Mail : sales@modéc.fr
Téléphone : +33 (0)4 75 40 27 15
Fax : +33 (0)4 75 40 27 36
www.modéc.fr

PRINT-NOT-KIT- ACCESSOIRES-EN-2022-V01