

# INSTRUCTION MANUAL

## MC89

ENGLISH

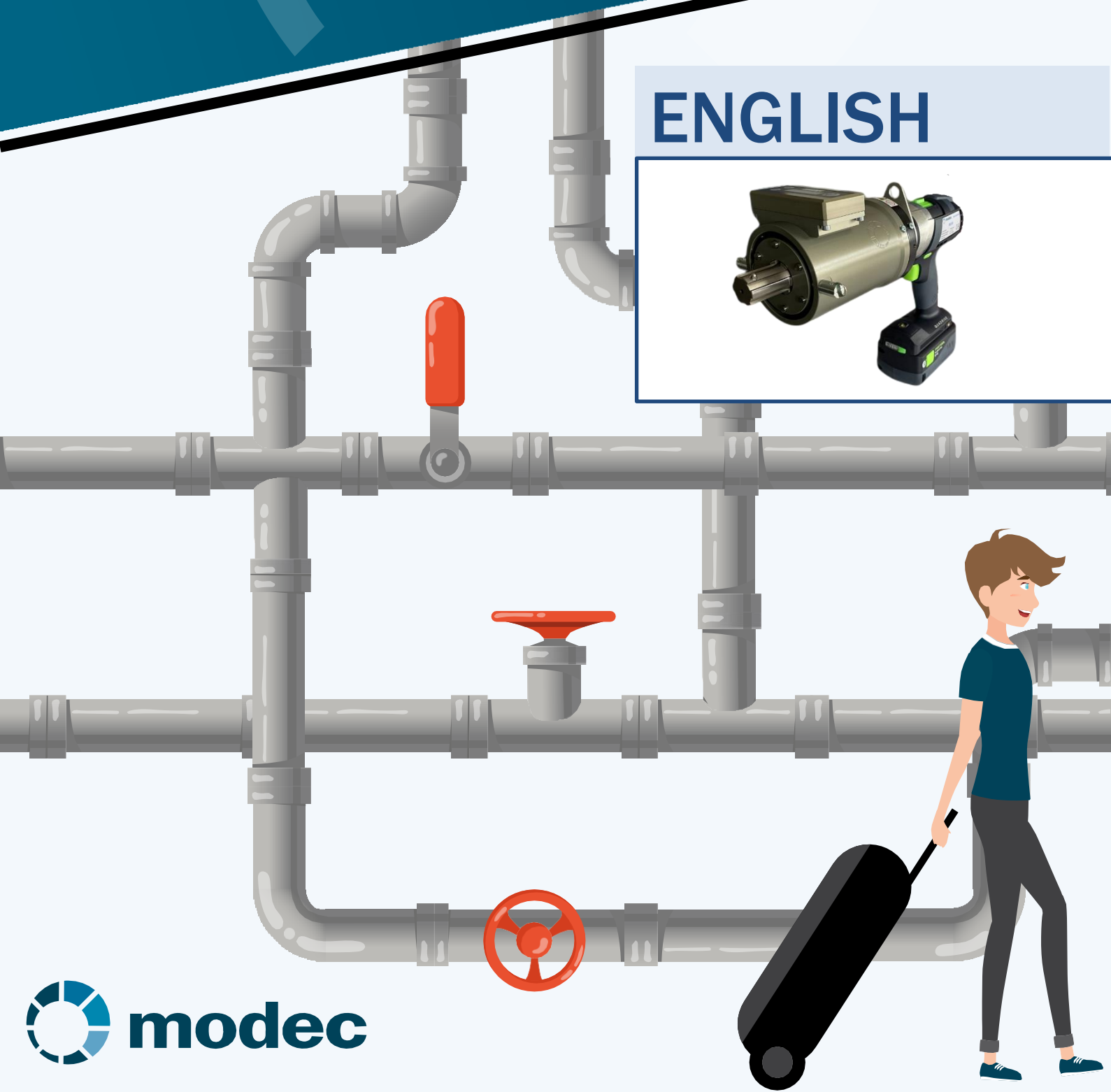

# TABLE OF CONTENT

1. Instruction manual .....	3
2. Introduction.....	4
3. General safety warnings.....	5
a. Transporting the actuator .....	7
b. Storing the actuator .....	7
c. Protecting the environment .....	7
4. CE certification.....	8
5. Safety equipment .....	9
6. Description and technical specifications.....	9
a. Portable Valve Actuator .....	9
b. Batteries and chargers .....	11
7. Starting up the Portable Valve Actuator .....	13
a. Changing the battery pack .....	13
b. Settings.....	13
8. Setting up the Portable Valve Actuator .....	17
a. General info.....	17
b. Fixing the actuator on to the torque management device and/or on an adaptor .....	17
c. Fixing the BR001 torque management arm and anchoring strap .....	18
9. Using the actuator .....	19
a. Preliminary checks .....	19
b. Torque reaction safety stop .....	19
c. Potential problems when actuating a valve .....	20
10. Revolution counter (option) .....	20
11. Maintenance and Servicing.....	22
12. Problem solving.....	23
13. Instruction Manual : modec Portable Valve Actuators .....	24
Warranty.....	25

# MC89E/S Electric series

## 1. Instruction manual

Light, powerful and fast, **moder** PVAs (Portable Valve Actuators) offer improved **safety** and **comfort** for operators and protect equipment from damage. They can be adapted to all types of handwheels, keys and valves, and have a torque that can reach up to 850 Nm (620 lb.ft).

They come with a large number of **options**, **adaptors** and **accessories** so they can be assembled to best meet the particularities of different maneuvering systems and their environment.

This makes it the perfect tool for any valve type, indoor or outdoor, with a great autonomy. Its two 18V **Lithium-Ion batteries** allow to use it continuously during **up to one hour**. For an even more intensive usage, use the **main power connection kit** that plugs on the actuator just like a battery and provides an **unlimited autonomy**.

Designed for any type of operation, the MC89 comes with 3 models only that cover a **0 to 450 rpm speed range** and a **850 Nm (620 lb.ft) maximum torque**. No need to say that even the most stubborn valves can be operated! No worry though, the **integrated electronic torque limiter** will easily prevent any damages for your valve or the tool itself. The integrated electronic torque limiter prevents from any risk of damaging the valve or the actuator itself.



CAREFULLY READ THE OPERATING HANDBOOK BEFORE USE



## 2. Introduction

This instruction manual must always be available and kept close to where the actuator will be used.

This document is unique and is owned by the company **modec**. It cannot be corrected, modified or duplicated without prior written agreement. This document should not be considered a replacement for safety rules set out in the Work Code or in any other legislation that applies to the site where the actuator is used.

It belongs to the operators to make sure that all security regulations applicable to both the work site and the Portable Valve Actuator conditions of use are respected.

**modec** products are conceived and fabricated with the utmost care and attention for the safety of both the operator and the equipment. This is certified by the declaration of conformity with the relevant clauses in the European directive 2006/42/CE.

The actuators described in this document may evolve. We reserve the right to modify their specifications, without prior notice. Updates will be available on our website [www.modec.fr](http://www.modec.fr). It is important to refer to the website before setting up or using the actuator, and before carrying out maintenance. Any modifications made to the actuators or their accessories must be approved in writing by **modec**.

Operators in charge of setting up, using or servicing **modec** actuators must have a reasonable knowledge of the equipment. As well as carefully reading this instruction manual, they must be competent in the valve sector and the particularities related to their work environment.



### **KEEP THESE INSTRUCTIONS**

**This manual contains important information and user instructions for the following tools: Electric Portable Valve Actuator MC89x-xxx-xx.**

**It is IMPERATIVE that you read the whole of this user guide before using the tool or carrying out any maintenance operations. Make sure you follow to the letter the instructions and diagrams found in this document. Failure to adhere to the instructions contained in this manual, and any modifications, omissions or the use of replacement parts that do not adhere to the specifications set out in this manual, clears the manufacturer of all responsibility related to the protection of people and equipment.**

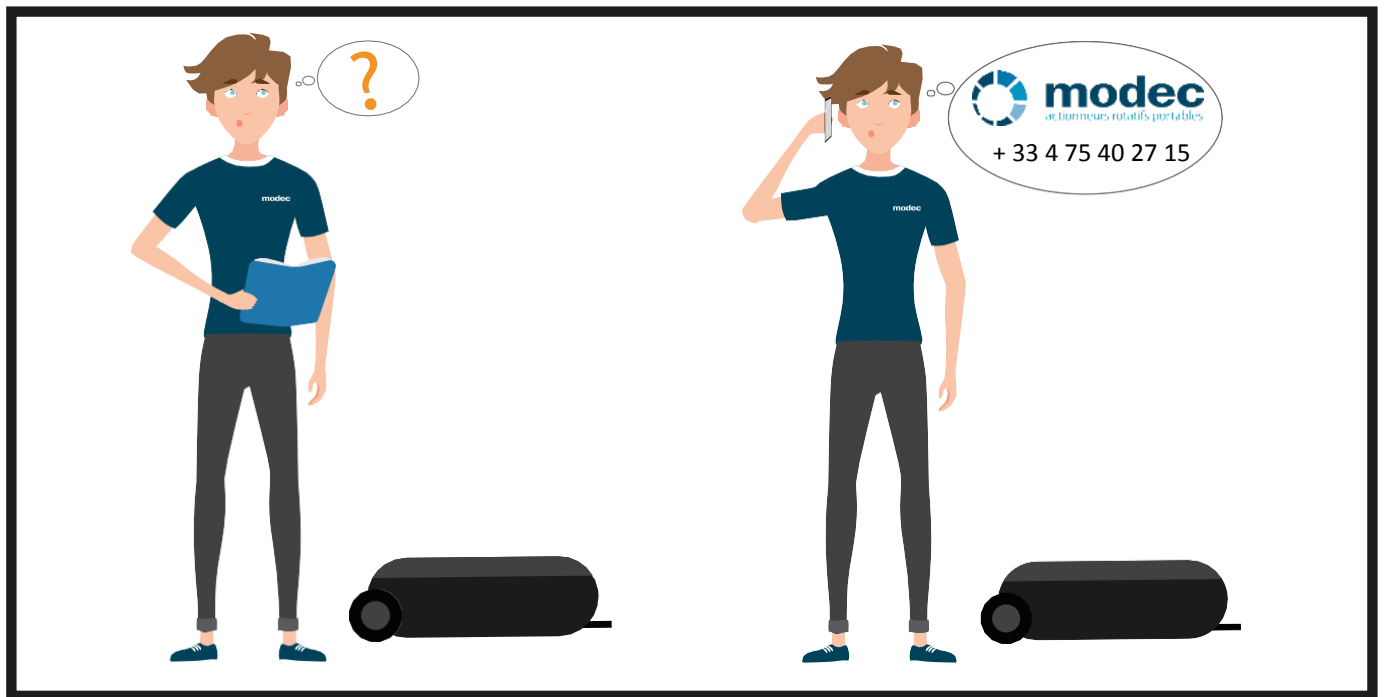

### 3. General safety warnings

**This machine is not intended for use by people with reduced physical, sensory or mental capacity, or by people devoid of experience or knowledge, except if they are supervised by, or have been given instructions by, an intermediary for the person responsible for their security.**

**Portable Valve Actuators are designed solely for use by professional operators trained in how to use them and educated about the relevant safety measures.**

 To avoid all risk of injury associated with using a **modtec** Portable Valve Actuator, take care to always follow the user instructions. Make sure you work in a comfortable position that demands minimal effort from your body, arms and wrists. Keep your wrists straight, without excessive, repetitive or prolonged twisting or extension. Don't use force and don't hold the tool tighter than necessary – avoid long exposure to vibrations.

- The **modtec** Portable Valve Actuator is a tool whose use is exclusively for manipulating valve handwheels or rotating systems, such as those described in this document.
- **modtec** Portable Valve Actuators are not adapted for manipulating winches or lifts.
- The company **modtec** declines all responsibility for damages caused by incorrect use and any use other than the one intended.
- The company **modtec** also declines all responsibility for damages resulting from the use of accessories that are not the original.

## **Work zone safety**

- Keep the work area clean and well-lit – minimum level lighting of 300 lux
- Aside from the operator, keep any other people at a safe distance within a radius that takes account of fixed points, straps, chains and any other torque retention system used.
- To protect the operator, we recommend that you do not use the PVAs if there is a risk of lightning.

## **Safety of personnel during use and maintenance**

- Stay vigilant – watch what you are doing and apply common sense when using the tool. Don't use a tool if you are tired or under the influence of drugs, alcohol or medicines.
- Use the individual safety protection equipment (see the summary table, page 7).
- Don't rush ahead – maintain a suitable position and balance at all times.
- Wear suitable clothing – don't wear baggy clothes or jewelry. It is obligatory to tie back hair and to wear close-fitting clothes (not floaty) to ensure all clothing parts are distanced when moving.
- To avoid the motor starting at the wrong time, before picking up or while carrying the PVA, remove or disconnect the battery and/or unplug the wire from the main.

## **Use and servicing**

- Don't use the tool if the switch systems for changing direction, accelerating, starting up or stopping are not working properly. This could pose danger to the operator.
- Observe tool maintenance. Check there if no incorrect alignment or blockage of moving parts or from broken parts or any other problem that could affect how the tool functions. If there is any damage, take the necessary steps and precautions to return the tool and its accessories to good working order.
- Have the tool serviced by a qualified repairer using only **modec** products when changing parts.
- Only use valve accessories recommended and approved by **modec**. Think to consult the accessory list provided and/or seek advice from **modec** for specific uses.
- Before starting up the motor, the operator must, without fail, check the follow points:
  - Accessories mounted or activated by the actuator are in good condition and correctly attached.
  - The most suitable torque retention system is being used and it assures the safety of the operator.
  - The system that fixes to the valve or the handwheel is adapted to the valve or handwheel being actuated.
  - Both the actuator and the operator are in a stable position. The operator is placed in opposition to any possible movements the actuator may make while coming to a stop.
- Stop the actuator immediately if it starts to behave differently (a change of noise, increased vibrations). Replace all damaged parts of the actuator and accessories. Damaged parts can burst and cause serious harm, even a potential fatality.
- Before placing a handwheel on, or removing it from, the actuator, wait until the actuator has come to a complete stop.
- Only activate the command to inverse the direction left/right when the actuator is fully stopped, otherwise the operator may find they are working in a poorly adapted position.
- Always hold down the rotation direction switch until it stops.



In certain circumstances, the tool may keep rotating for several seconds after releasing the switch. Never put your hands close to the tool or any moving parts.

- Keep the ventilation slits on the actuator and the batteries free and clean to ensure adequate cooling.
- Keep the contacts on the machine, charger and battery pack clean.
- Don't open the battery. Risk of short-circuiting.
- Protect the battery from heat, for example direct exposure to the sun, to fire, to water and to humidity. There is a risk of explosion.
- In case of damage or non-conforming use of the battery, vapors could escape. Ventilate the work place and consult a doctor if you feel unwell.



### **a. Transporting the actuator**

- Keep the original casing for return in case of any revisions or repairs.
- When packing, make sure that all switches are off and without any constraints.
- Always pack the tools in the correct spaces to avoid them knocking against each other.
- Replace the batteries in their allotted casing.
  - Lithium-ion batteries are subject to rules regulating the transport of dangerous materials. The operator can transport the batteries by road without taking any additional measures.
  - When transporting via a third party (for example, by air or a via a transport company), you must conform to the specific measures regarding packaging and labelling. In such a case, it is imperative to take advice from an expert in the transport of dangerous materials when preparing the transportation. Only send the batteries if the packaging is not damaged. Recover any unprotected contacts and pack the batteries tightly so they cannot move about. Please also follow any additional regulations that may apply.

### **b. Storing the actuator**

**modec** actuators must be stored in a dry and correctly ventilated environment to ensure there is no corrosion of the internal mechanic parts.

### **c. Protecting the environment**

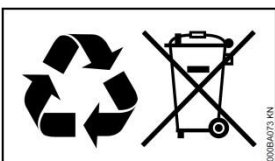

To eliminate waste, conform to the stated national requirements. The actuators and their accessories must not be thrown in a waste bin. Make sure you dispose of the tools in specialist recycling centers.

# CERTIFICATE OF EC COMPLIANCE

THE UNDERSIGNED MANUFACTURER

MODEC SAS  
ZI SIRIUS QUATRE, 80 ALLÉE RENÉ HIGONNET  
F-26760 BEAUMONT LÈS VALENCE  
N° SIRET : 493 748 917 00017

DECLARES THAT THE PORTABLE VALVE ACTUATOR DESIGNATED BY THE FOLLOWING COMMERCIAL REFERENCES:

<u>TYPE</u>	<u>DESIGNATION</u>	<u>SERIAL NUMBER</u>
PNEUMATIC		
HL83E-xxx-xx	AIR PORTABLE ACTUATOR, EASY DUTY,	HL83E-XXXXXXXX
HL83S-xxx-xx	AIR PORTABLE ACTUATOR, STANDARD DUTY	HL83S-XXXXXXXX
HL83H-xxx-xx	AIR PORTABLE ACTUATOR, HEAVY DUTY	HL83H-XXXXXXXX
PETROL GAS		
PY68E-xxx-xx	GAS PORTABLE ACTUATOR, EASY DUTY	PY68E-XXXXXXXX
PY68S-xxx-xx	GAS PORTABLE ACTUATOR, STANDARD DUTY	PY68S-XXXXXXXX
PY68H-xxx-xx	GAS PORTABLE ACTUATOR, HEAVY DUTY	PY68H-XXXXXXXX
ELECTRIC		
MC89E-xxx-xx	ELECTRIC PORTABLE ACTUATOR, EASY DUTY	MC89E-XXXXXXXX
MC89S-xxx-xx	ELECTRIC PORTABLE ACTUATOR, STANDARD DUTY	MC89S-XXXXXXXX
JA73E-xxx-xx	ELECTRIC PORTABLE ACTUATOR, EASY DUTY	JA73E-XXXXXXXX
JA73S-xxx-xx	ELECTRIC PORTABLE ACTUATOR, STANDARD DUTY	JA73S-XXXXXXXX
JA73H-xxx-xx	ELECTRIC PORTABLE ACTUATOR, HEAVY DUTY	JA73H-XXXXXXXX

COMPLIES WITH THE ESSENTIAL REQUIREMENTS OF THE EUROPEAN DIRECTIVE 2006/42/EC

BEAUMONT LÈS VALENCE, JAN 01, 2023

MR PIERRE-YVES COTE  
PRÉSIDENT

SIGNATURE :

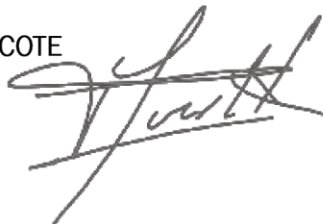

SCAN THE QR CODE AND FIND THE PORTABLE VALVE ACTUATORS  
EC CERTIFICATE IN YOUR LANGUAGE



**modéc**  
portable valve actuators



## 5. Safety equipment

### Personal Protective Equipment :

Operators or anyone placed close to the actuators must wear the following protection. It is incumbent on the company using the equipment to ensure that safety rules are respected.



Hearing protection



Protective goggles



Safety shoes



Safety gloves

### Safety signs :

Summary table explaining the pictograms found on the apparatus.



Warning ! Using this material can be dangerous



Read the notice, before use



Risk of fire



Do not use in the rain or in damp surroundings

## 6. Description and technical specifications

### a. Portable Valve Actuator

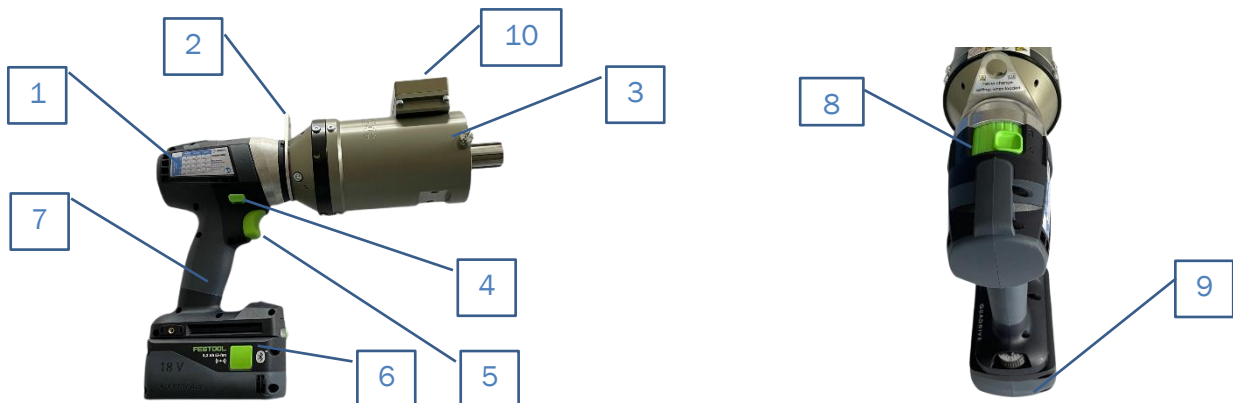

- 1 – Information stickers : Indicate for each rotation direction (D1 & D2) the possible torque settings depending on the Banjo head used
- 2 – Fixation ring to fix a strap for handling and carrying: Not for torque management.
- 3 – Flange: enables the attachment of all **modec** heads, adaptors and torque systems.
- 4 – Left/right switch – to choose rotational direction of the actuator.
- 5 – Start / Stop trigger: For a progressive start and to stop the actuator when released.
- 6 – Removable battery: The mains connection can also be plugged at this place.
- 7 – Isolated handle (grey zone) : Do not use as a torque reaction device.
- 8 – Speed control button (4 possible positions).
- 9 – Electronic torque limiter thumbwheel (13 possible positions).
- 10 – Revolution counter module (option): it gives a double reading – rotating speed and number of turns.

## Performances & technical characteristics

Straight or with RA30	Free speed (rpm)	Max torque (Nm (lb.ft))	Weight kg (lb)	Dimensions (l x d x h) mm (in)
MC89E-007	450	115 (85)	5,1 (11.2)	354 x 96 x 269 (13.9"x3.78"x10.6")
MC89S-035	94	550(400)*	5,1 (11.2)	354 x 96 x 269 (13.9"x3.78"x10.6")
MC89S-054	61	850(630)*	5,4 (11.9)	367 x 96 x 269 (14.4"x3.78"x10.6")

\* **Warning ! Do not use the RA30 right angle head with a torque > 600 Nm (440 lb.ft), use the torque limiter (see table below) All performance values indicated above have a +/-5% accuracy**



### Use with a Banjo head

Banjo heads enable to use the actuator on a handwheel with a rising stem. They also add a gear ratio to the system by reducing the speed and increasing the torque by 4 for the BJH01 and by 3 for the BJH02. However, the BJH01 cannot withstand an output torque higher than 600 Nm (440 lb.ft). As a consequence, the input torque should not exceed 150 Nm (110 lb.ft). The BJH02 cannot withstand an output torque higher than 1000 Nm (740 lb.ft). As a consequence, the input torque should not exceed 330 Nm (240 lb.ft).

When using a Banjo head, it is essential to set the electronic torque limiter so that the input torque will not exceed 150 Nm (110 lb.ft) for the BJH01 and 1000 Nm (740 lb.ft) for the BJH02.

Failure to observe these precautions can lead to premature aging of the banjo head and even breakage.

With Banjo head BJH01	Free speed (rpm)	Max torque (Nm (lb.ft))
MC89E-007	113	460 (340)
MC89S-035	24	600 (440)*
MC89S-054	14	600 (440)*

\* **Warning ! The maximum acceptable torque for the BJH01 is 600 Nm (440 lb.ft). Do not use the BJH01 if the torque required is higher than 600 Nm (440 lb.ft), use the torque limiter to limit the input torque to 150 Nm (110 lb.ft) (see stickers on the actuator and table hereafter)**

With Banjo head BJH02	Free speed (rpm)	Max torque (Nm (lb.ft))
MC89E-007	150	350 (260)
MC89S-035	31	1000 (740)*
MC89S-054	20	1000 (740)*

\* **Warning ! The maximum acceptable torque for the BJH02 is 1000 Nm (740 lb.ft). Do not use the BJH02 if the torque required is higher than 1000 Nm (740 lb.ft), use the torque limiter to limit the input torque to 330 Nm (240 lb.ft) (see stickers on the actuator and table hereafter)**

## Sound and vibration levels

Sound and vibration levels are calculated based on the conditions of use at the maximum rated speed. Values apply to the core tool (without added options or accessories). The values can vary significantly depending on the equipment to which the tool is applied. The end operator should establish the actual measurements.

Maximum level of weighted acoustic pressure A at the operator's location	<b>L<sub>PA</sub> = 73 dB(A)</b>
Maximum level of weighted acoustic power A at the operator's location	<b>L<sub>WA</sub> = 84 dB(A)</b>

Uncertainty of measure	K = 3 dB
------------------------	----------

Values established from an equivalent apparatus.

Value of vibration emission	Ah < 2,5 m/s <sup>2</sup>
-----------------------------	---------------------------

Uncertainty of measure	K = 1,5m/s <sup>2</sup>
------------------------	-------------------------

Values established from an equivalent apparatus. Electric motor voltage : 18V DC

## b. Batteries and chargers

### Chargers

Technical data	BAT145	BAT146
Mains voltage (input)	220-240 V AC	220-240 V AC
Mains frequency	50 / 60 Hz	50 / 60 Hz
Charging voltage (output)	10,8 – 18 V DC	10,8 – 18 V DC
Rapid charging	Max 6A	Max 8A
Permitted charging temperature range	-5°C / +55°C	-5°C / +55°C
Safety class	II	II
Weight	0,8 kg	1,1 kg

SCA 8

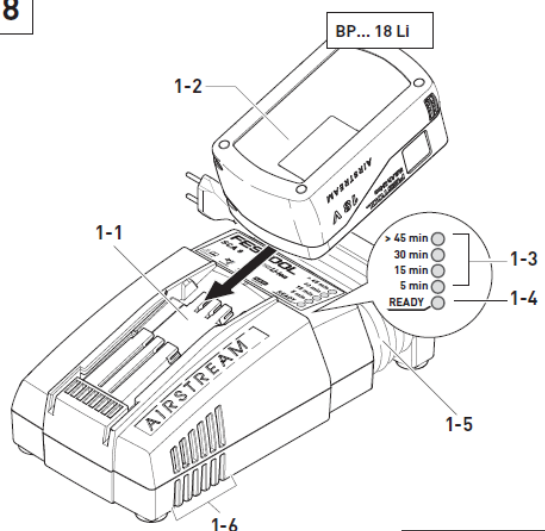

Quick charger BAT146

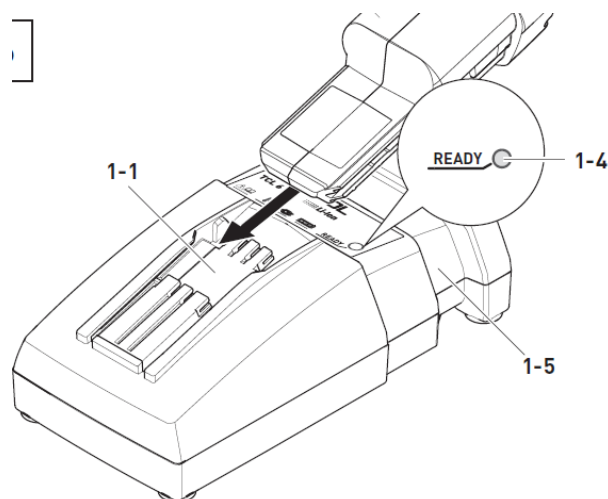

Standard charger BAT 145

- 1-1 : Charging station
- 1-2 : Battery pack
- 1-3 : Remaining charge time display (BAT146 only)
- 1-4 : Charge status display
- 1-5 : Cable holder
- 1-6 : Vents (BAT146 only)

### Start charging :

Before use, the cable must be completely unwound from the recess (1-5).

- Insert the charger mains plug in the socket.
- Push the battery pack (1-2) into the charging station (1-1)

**Meaning of the LEDs :**

After plugging the charger in the socket, all the LEDs light up for approx 1 sec. (BAT146 only). Then, the charge status display (1-4) on the charger initially changes to the yellow LED (« self-check ») and then indicates the operating condition of the charger :

- Steady yellow LED : Charger is ready for operation
- Flashing green LED : Battery pack is charging
- Steady green LED : The battery pack is more than 80% charged and ready for use. In the background, the battery pack will continue to be charged up to 100%.
- Flashing red LED : General fault indicator, e.g. not in full contact, short circuit, faulty battery pack, etc.
- Steady red LED : Battery temperature is outside the permitted limit values. As soon as the permitted temperature is reached, the charger automatically switches to charging.
- On the BAT146 only, the maximum remaining charging time is indicated on the LEDs (1-3)

**Batteries**

Technical data	BAT143	BAT144
Voltage	18 V DC	18 V DC
Capacity	5,20 Ah	6,20 Ah
Autonomy*	24 minutes	29 minutes
Charging time with standard charger BAT145	45 minutes	53 minutes
Charging time with quick charger BAT146	33 minutes	40 minutes
Weight	0,7 kg	0,7 kg

\*Autonomy is measured with a load equal to 50% of the max torque

**Instructions for use :**

**BP 18 Li AS**

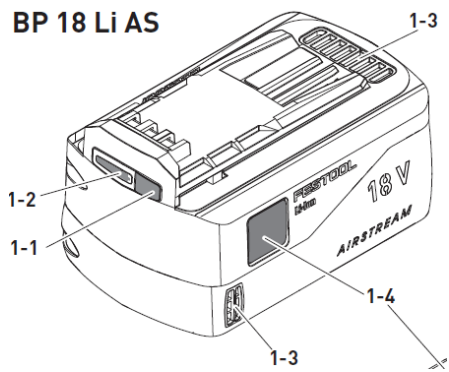

The battery pack is delivered partially charged. To guarantee that the battery pack provides full power, charge it completely in the charger before using it for the first time. It can be charged at any time without reducing the battery life. Interrupting the charging process does not damage it. The battery pack is fitted with a temperature sensor, which only permits charging at temperatures of between 0 °C to 55 °C. This ensures a longer battery life.

The battery pack should ideally be stored in a cool (5°C to 25°C) and dry location (air humidity < 80 %). Significantly shorter operating times after each charge indicate that the battery pack is worn and should be replaced with a new one. Observe instructions regarding disposal.

**Capacity display:**

When pressing the button,[1-1] the charge indicator [1-2] shows the charge of the battery pack during approx. 2 s :

- 3 LED : Battery pack is charged > 70%
- 2 LED : Battery pack is charged between 40% and 70%
- 1 LED : Battery pack is charged between 15% and 40%

- 1 LED flashing: Battery pack is charged < 15% → Charge the battery pack before any further use. Do not continue until complete discharge.

After the portable actuator has switched off automatically, do not press the on/off button, this could damage the battery pack.

## 7. Starting up the Portable Valve Actuator

### a. Changing the battery pack

- **INSERTING / REMOVING THE BATTERY**

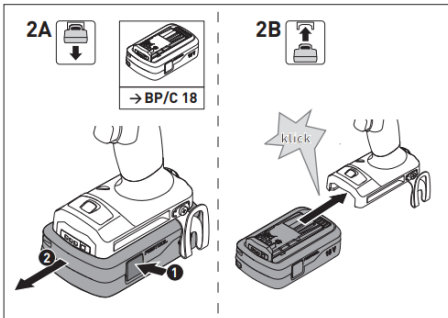

Before using the battery pack, check that the battery interface is clean. Any contamination of the battery interface may impair correct contact and lead to the contacts being damaged. A faulty contact may result in the machine overheating or being damaged.

### b. Settings



Risk of injury! Only adjust the settings when the power tool is switched off and free of any load.

- **CHANGING DIRECTION OF ROTATION**

- Switch to the left = “D1” rotation direction / Right / clockwise
- Switch to the right = « D2 » rotation direction / Left / counterclockwise

- **SETTING TORQUE LIMIT AND SPEED**

The maximum speed value can be set with the Speed control trigger (8) on the top of the actuator. There are 4 possible positions. The torque limit can be set with the thumbwheel located at the bottom back of the actuator.

Each combination of speed and torque settings provide different rotational speeds and torque limits. The matrix hereafter shows the values for each combination. Once the desired torque limit is reached, the actuator beeps twice and stops. It restarts only after releasing and pressing the power switch again

The torque also depends on the selected speed:

Pos 1: Moderate speed / Max torque

Pos 4: Max speed / Moderate torque

• **TORQUE / SPEED MATRIX MC89E-007**

Speed setting	Torque lim. setting	1	2	3	4	5
1	Max S (rpm)	37	42	48	53	59
	Max T (Nm) (lb.ft)	12(9)	38 (28)	62 (46)	90 (66)	115 (85)
2	Max S (rpm)	59	66	74	81	88
	Max T (Nm) (lb.ft)	11(8)	34 (25)	57 (42)	81 (60)	107 (79)
3	Max S (rpm)	180	210	240	270	300
	Max T (Nm) (lb.ft)	3 (2)	11 (8)	20 (15)	28 (20.5)	37 (27)
4	Max S (rpm)	280	320	370	400	450
	Max T (Nm) (lb.ft)	2 (1.5)	7,5 (5.5)	14 (10.5)	20 (14.5)	26 (19)

• **TORQUE / SPEED MATRIX MC89E-007 WITH BJH01**

Speed setting	Torque lim. setting	1	2	3	4	5
1	Max S (rpm)	9	11	12	13	15
	Max T (Nm) (lb.ft)	48 (35.5)	152 (112)	248 (183)	360 (265.5)	460 (339)
2	Max S (rpm)	15	17	19	20	22
	Max T (Nm) (lb.ft)	44 (32.5)	136 (100)	228 (168)	324 (239)	428 (315)
3	Max S (rpm)	45	53	60	68	75
	Max T (Nm) (lb.ft)	12 (9)	44 (32.5)	80 (59)	112 (82.5)	148 (109)
4	Max S (rpm)	70	80	93	100	113
	Max T (Nm) (lb.ft)	8 (6)	30 (22)	54 (40)	80 (59)	104 (76.5)

• **TORQUE / SPEED MATRIX MC89E-007 WITH BJH02**

Speed setting	Torque lim. setting	1	2	3	4	5
1	Max S (rpm)	12	14	16	18	20
	Max T (Nm) (lb.ft)	36 (26.5)	114 (84)	186 (137)	270 (199)	345 (254)
2	Max S (rpm)	20	22	25	27	29
	Max T (Nm) (lb.ft)	33 (24)	102 (75)	171 (126)	243 (179)	321 (237.5)
3	Max S (rpm)	60	70	80	90	100
	Max T (Nm) (lb.ft)	9 (6.5)	33 (24)	60 (44)	84 (62)	111 (82)
4	Max S (rpm)	93	107	123	133	150
	Max T (Nm) (lb.ft)	6 (4.5)	22,5 (16.5)	41 (30)	60 (44)	78 (57.5)

• **TORQUE / SPEED MATRIX MC89S-035**

Speed setting	Torque lim. setting	1	2	3	4	5
1	Max S (rpm)	8,0	9,0	10	11	12
	Max T (Nm) (lb.ft)	60 (44)	180 (132.5)	300 (221)	430 (317)	550 (405.5)
2	Max S (rpm)	12	14	15	17	18
	Max T (Nm) (lb.ft)	50 (37)	160 (118)	270 (199)	390 (287.5)	515 (380)
3	Max S (rpm)	38	44	51	57	63
	Max T (Nm) (lb.ft)	13 (9.5)	50 (37)	100 (73.5)	140 (103)	175 (129)
4	Max S (rpm)	58	67	77	84	94
	Max T (Nm) (lb.ft)	10 (7.5)	35 (26)	65 (48)	95 (70)	125 (92)

- Settings acceptable for BJH01 & BJH02
- Settings acceptable for BJH02 only
- Use of BJH impossible with these settings

• **TORQUE / SPEED MATRIX MC89S-035 WITH BJH01**

Speed setting	Torque lim. setting	1	2	3	4	5				
1	Max S (rpm)	2	Forbidden							
	Max T (Nm) (lb.ft)	240 (177)								
2	Max S (rpm)	3								
	Max T (Nm) (lb.ft)	200 (147.5)								
3	Max S (rpm)	10					11	13	14	
	Max T (Nm) (lb.ft)	52 (38.5)					200 (147.5)	400 (295)	560 (413)	
4	Max S (rpm)	15	17	19	21	24				
	Max T (Nm) (lb.ft)	40 (29.5)	140 (103)	260 (192)	380 (280)	500 (369)				

• **TORQUE / SPEED MATRIX MC89S-035 WITH BJH02**

Speed setting	Torque lim. setting	1	2	3	4	5		
1	Max S (rpm)	3	3	3	Forbidden			
	Max T (Nm) (lb.ft)	180 (132.5)	540 (398)	900 (664)				
2	Max S (rpm)	4	5	5				
	Max T (Nm) (lb.ft)	150 (110.5)	480 (354)	810 (597.5)				
3	Max S (rpm)	13	15	17			19	21
	Max T (Nm) (lb.ft)	39 (28.5)	150 (110.5)	300 (221)			420 (310)	525 (387)
4	Max S (rpm)	19	22	26	28	31		
	Max T (Nm) (lb.ft)	30 (22)	105 (77.5)	195 (144)	285 (210)	375 (276.5)		

• **TORQUE / SPEED MATRIX MC89S-054**

Speed setting	Torque lim. setting	1	2	3	4	5
1	V (tr/min)	5,0	5,8	7	7	8
	Cmax (Nm) (lb.ft)	90 (66.5)	280	460	660	850
2	V (tr/min)	8,0	9,0	10	11	12
	Cmax (Nm) (lb.ft)	80 (59)	250	420	600	790
3	V (tr/min)	25	29	33	37	41
	Cmax (Nm) (lb.ft)	20 (14.5)	80	150	210	270
4	V (tr/min)	38	44	50	55	61
	Cmax (Nm) (lb.ft)	15 (11)	55	100	145	190

- Settings acceptable for BJH01 & BJH02
- Settings acceptable for BJH02 only
- Use of BJH impossible with these settings

• **TORQUE / SPEED MATRIX MC89S-054 WITH BJH01**

Speed setting	Torque lim. setting	1	2	3	4	5
1	V (tr/min)	1	<b>Forbidden</b>			
	Cmax (Nm) (lb.ft)	360 (265.5)				
2	V (tr/min)	2				
	Cmax (Nm) (lb.ft)	320 (236)				
3	V (tr/min)	6				
	Cmax (Nm) (lb.ft)	80 (59)	320 (236)	600 (442.5)		
4	V (tr/min)	10	11	13	14	
	Cmax (Nm) (lb.ft)	60 (44.5)	220 (162)	400 (295)	580 (428)	

• **TORQUE / SPEED MATRIX MC89S-054 WITH BJH02**

Speed setting	Torque lim. setting	1	2	3	4	5
1	V (tr/min)	2	2	<b>Forbidden</b>		
	Cmax (Nm) (lb.ft)	270 (199)	840 (619.5)			
2	V (tr/min)	3	3			
	Cmax (Nm) (lb.ft)	240 (177)	750 (553)			
3	V (tr/min)	8	10			
	Cmax (Nm) (lb.ft)	60 (44)	240 (177)	450 (332)	630 (464.5)	810 (597.5)
4	V (tr/min)	13	15	17	18	20
	Cmax (Nm) (lb.ft)	45 (33)	165 (121.5)	300 (221)	435 (321)	570 (420.5)



## 8. Setting up the Portable Valve Actuator

### a. General info

 The actuator must be kept stable while turning the valve or handwheel. **modec** Portable Valve Actuators can be used in any position.

However, to ensure the operator is working safely and in the best conditions, it is imperative that the actuator is used in the axis of the handwheel being activated.

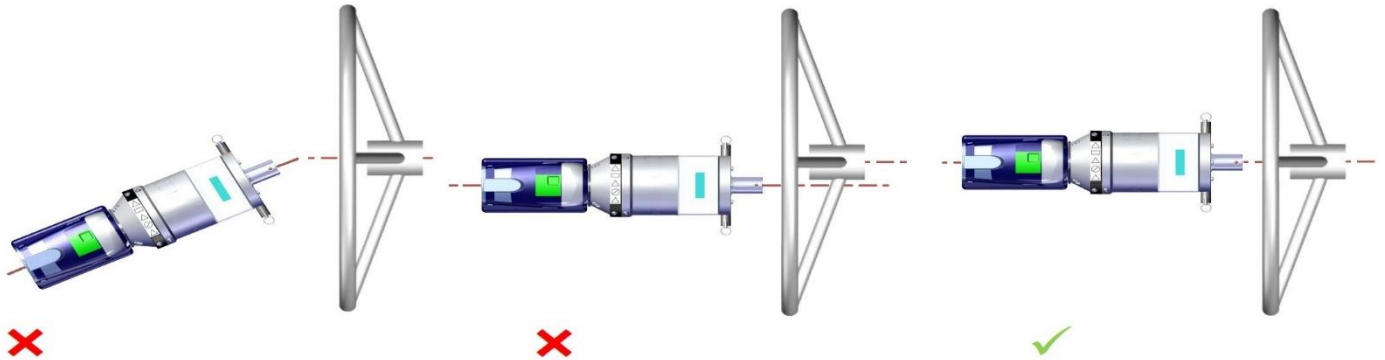

NB: These diagrams are made with one of the **modec** actuators. However, the head (flange and output shaft) being identical on all actuators, they apply in the same way to all the actuators of the range.

### b. Fixing the actuator on to the torque management device and/or on an adaptor

 To ensure the operator is working safely and in optimum conditions, it is imperative to use a torque retention system.

Our actuators are delivered with:

- A BR001 torque management reaction bar
- A strap or a chain
- 2 carabiners.

In addition to this basic pack, **modec** also has a wide range of torque management accessories (see the catalogue and the following presentation for more details).

As well as these standard accessories, **modec** develops specific systems. If you would like to check your installation or if you have a specific solution request, contact a registered **modec** distributor”

Besides this torque retention rod, it is also possible using the “**modec** standard” flange and shaft to fix the system to RA30 right-angled models, to BJH hollow heads and all **modec** torque management accessories (see catalogue).

If the standard equipment does not provide a torque retention that offers sufficient safety for

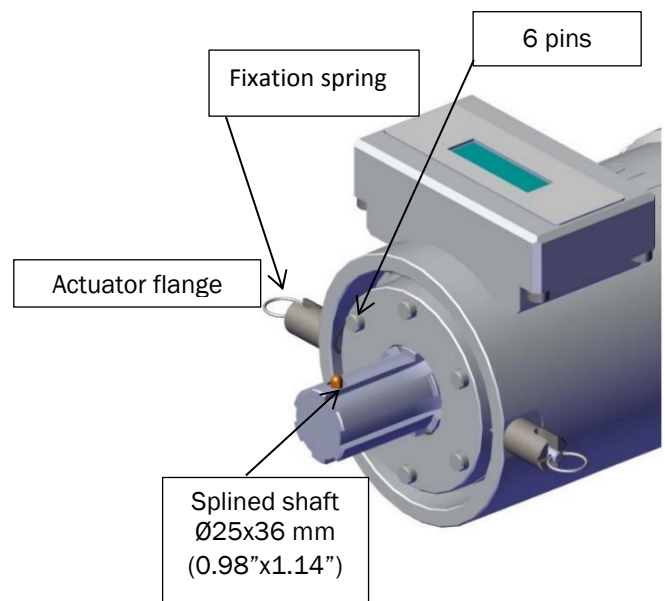

both operators and equipment, **modec** can develop and/or adapt special torque management systems.

**⚠** Never use a portable actuator with a torque management system that is under-sized, unstable or badly positioned.

**c. Fixing the BR001 torque management arm and anchoring strap**

Pull each fixation spring with the ring and rotate for a quarter turn so that they stay in the pulled position. Place the black ring of the torque management bar on the flange so that the 6 pins enter the corresponding holes. Make a quarter turn with the fixation springs rings and release the springs making sure they come back. Check that the torque management bar is properly secured to the flange.

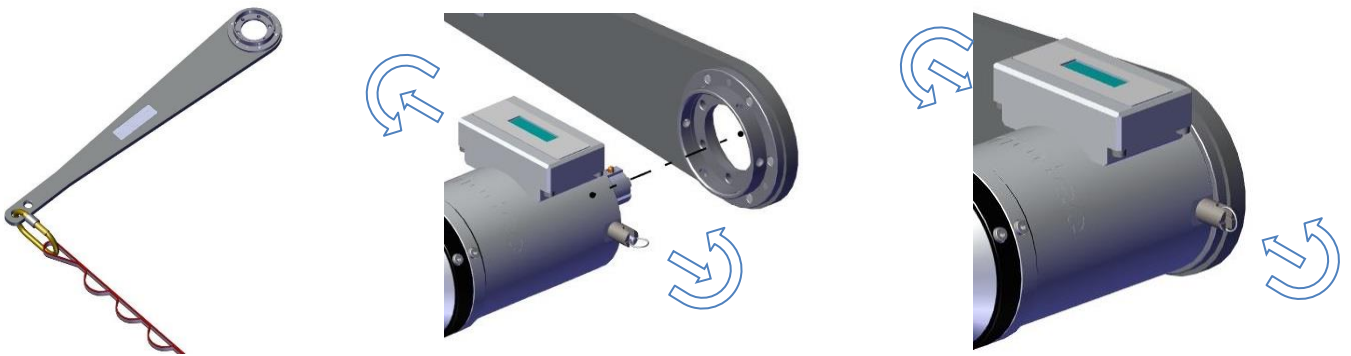

**Setting the system for rotation “D1”**

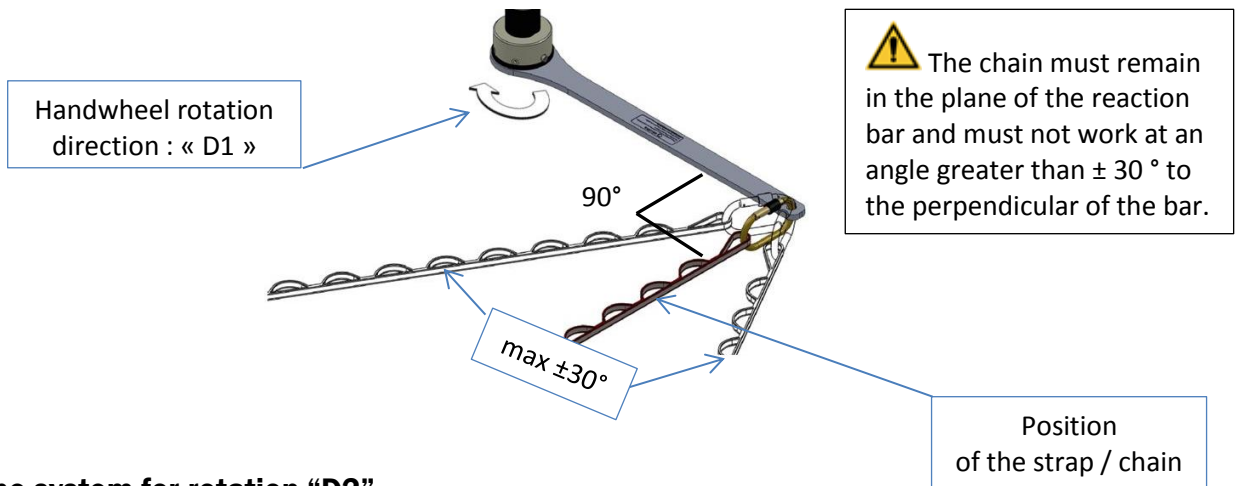

**Setting the system for rotation “D2”**

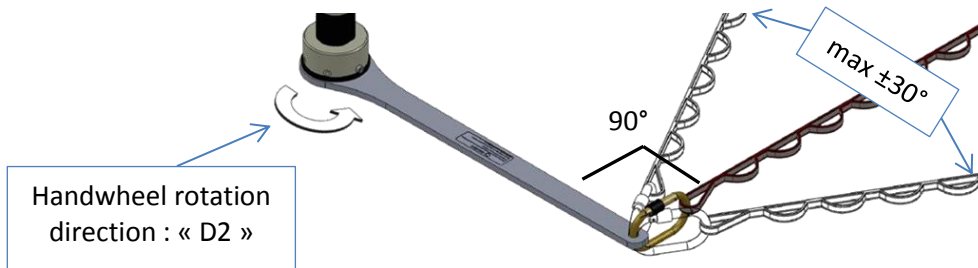

**⚠** Except if otherwise engraved on the torque reaction system, the maximum torque is 1000 Nm (740 lb.ft)

## 9. Using the actuator

### a. Preliminary checks



1 – Check the equipment is in good condition and use accessories that are the most suitable for the actuator.

**Make sure the torque management system and the handwheel adapter are compatible with the action about to be carried out.**

2 – Insert the battery. Set the torque limiter to minimum.

3 – Check the rotational direction required for the valve or the handwheel. Set the defined rotation direction using the actuator's left/right switch.

4 – Position the adaptor on the valve and set up the torque retention system. Consult the instructions for adaptors.

5 – Check that the strap is fixed on the appropriate side of the reaction bar depending on the rotation direction

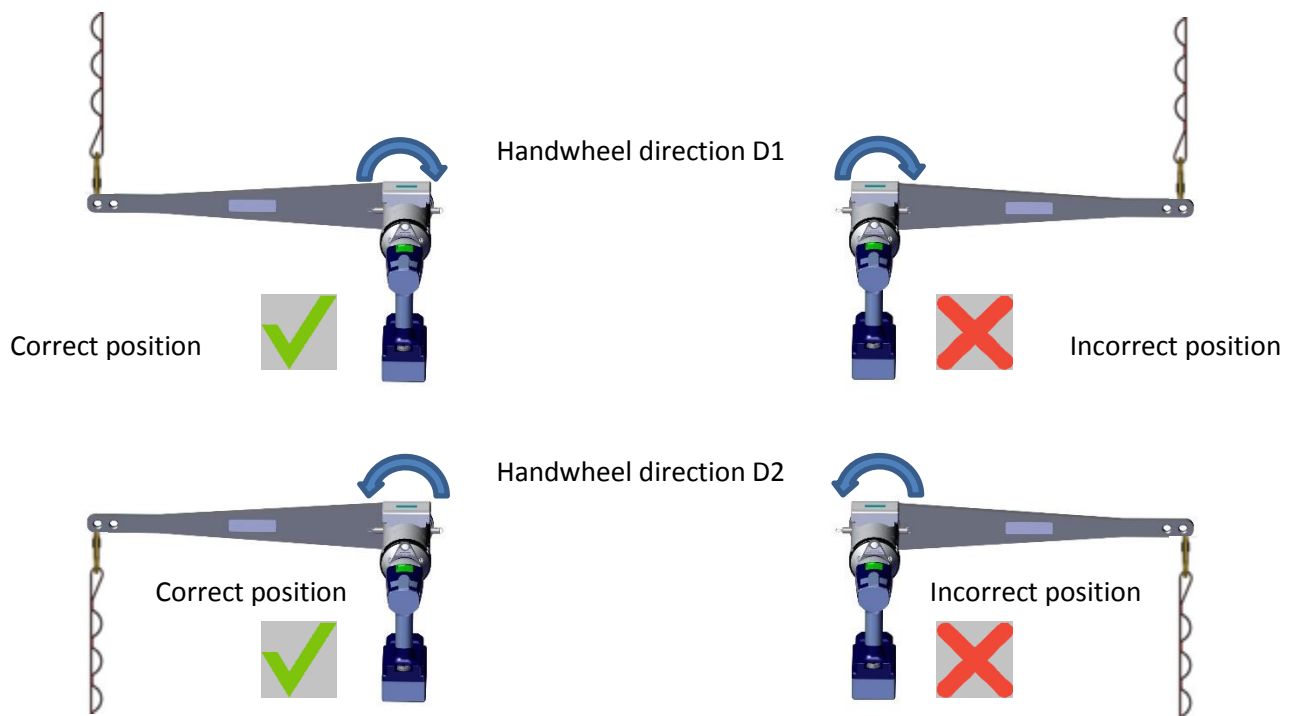

6 – When starting up, **always start up slowly** in order to **VERIFY** the rotational direction, and to put tension on the torque retention strap or chain.

### b. Torque reaction safety stop

In case you don't use a torque reaction system or you don't install it correctly, the actuator may rotate suddenly and unexpectedly when started. If the rotation speed is high, this may be dangerous for the user. In such a case, in order to protect users, the actuator will switch off, beep once, and the LED light will flash continuously.

- Release the On/Off switch
- Install a correct torque reaction system
- Press the On/Off switch again

### c. Potential problems when actuating a valve

1 – If the actuator sounds a “beep” it means that the required torque is higher than the torque limit set. Increase progressively the torque limit and try again.

 **Make sure that the torque limit set doesn't exceed the valve maximum allowed torque**

2 – If the actuator is still unable to start even with a high (or maximum) torque limit, the valve may be fully open or closed and the selected direction of rotation may not be correct. In this case, repeat the procedure from the beginning by changing the direction of rotation of the actuator.

 **Check again the direction of the torque retention.**

3 – In case of resistance resulting from deposits on the stem, turn the valve in both directions several times to ‘clean’ it. **modec** revolution counter (optional) enables you to always know which position the valve is in.

4 – When the closed position is reached, make sure the torque does not exceed the valve maximum allowed torque. Unless the procedure indicates otherwise, reopen the valve with a few turns so that the accelerated fluid “cleans” any potential impurities from the valve, then close it again at the desired torque.

5 – When the maximum open position is reached, reclose with a few turns to avoid the valve getting stuck in future. Doing this also means that the valve is still able to turn when next actuated even if the operator turns it the wrong way, which again helps prevent the valve being stuck.

## 10. Revolution counter (option)

### • PRESENTATION

The digital Revolution counter adds up the revolutions in one direction and subtracts them in the other direction in such a way that the operator always knows where he is in relation to the initial set-up. The tool also measures and shows the rotational speed.

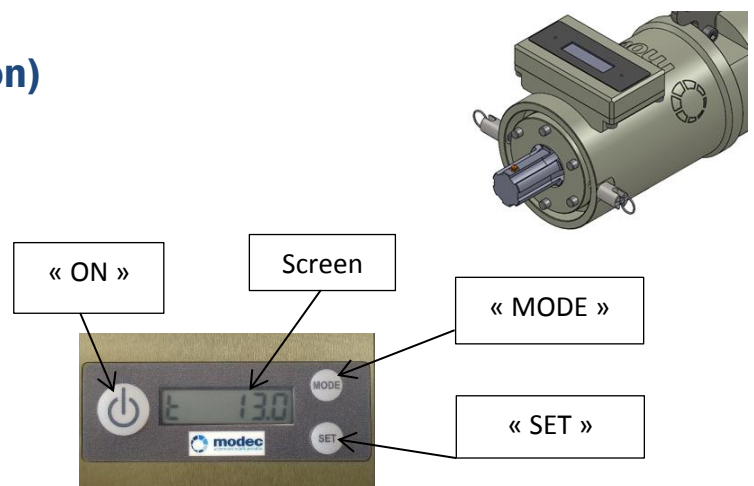

**Note 1 :** The instant speed indicator needs several revolutions before it can give a stable and regular speed. In light of this, you have to wait several seconds to get a reliable reading.

**Note 2 :** The screen turns itself off after 5 minutes.

• **HOW IT WORKS**

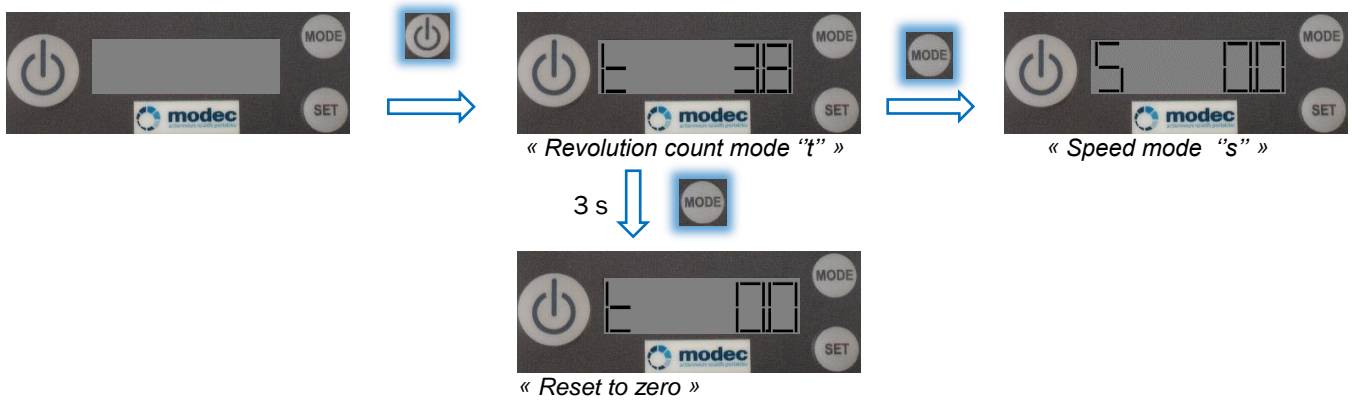

• **REVOLUTION COUNTER PARAMETERS**

The revolution counter is set by default for a straight or right angle head (RA30) standard output shaft (STD), without Banjo head.

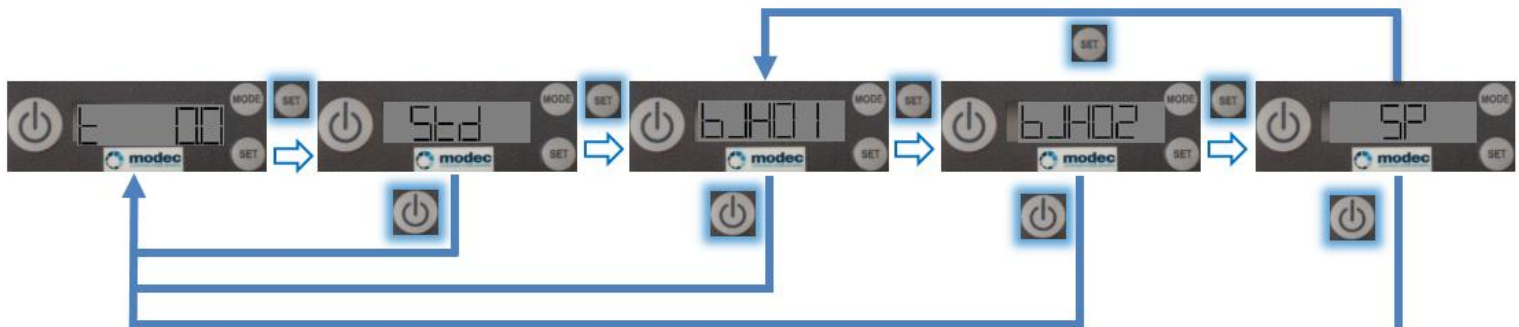

When used with a BJB banjo head (see chapter 8), the number of turns and the output speed of the actuator will be different, so you need to select “BJH01” for a standard duty Banjo head (speed is divided by 4) or “BJH02” for a heavy duty Banjo head (speed is divided by 3).

If you want to set a specific ratio for speed and count, select “SP”, then indicate if you want to multiply (“M”) or divide (“d”) the speed and number of turn, and set the ratio “l=” from 1.0 to 20.0

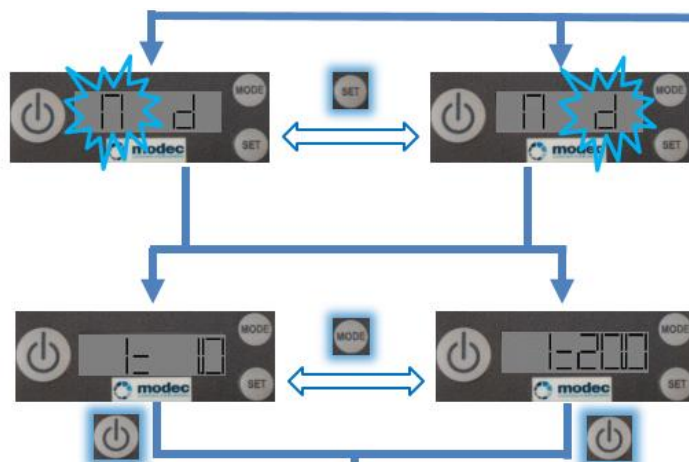

• **CHANGING THE BATTERY**

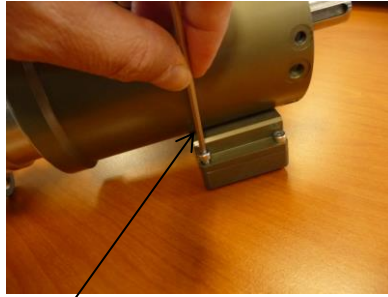

Use a 3mm (1/8") hexagonal key



Use a AA 3,6V Li-SOCL2 battery  
Reposition the wires correctly before tightening the 4 screws

**11. Maintenance and Servicing**

Take the machine to a registered **modec** distributor for servicing every 400 hours or at least once a month.

Maintenance operation	Weekly	Yearly or as needed
Check and service the actuator by a registered <b>modec</b> distributor		
Replace the Revolution counter battery *		
Check the torque limiter* by a registered <b>modec</b> distributor		

\*The revolution counter is an option

Maintenance to be carried out at the indicated intervals in months or in hours of use, from the first deadline onwards.			Interval			
Range	Parts	Task	After each time	Every 3 months or 25 hours	Every 6 months or 50 hours	Every year or 100
MC89	Condition of the tool and protective elements	Check	U			
MC89	Functioning of the triggers and Stop/Start button	Check	U			
MC89	Functioning of the setting systems for the torque, speed and direction inversion	Check	U			
MC89	Condition of the cables and/or leads	Check	U			

U : user – M : **modec** registered distributor / repairer

**General recommendations**

- Take note of all the work health and safety regulatory provisions that apply and any local workplace safety instructions including conditions relating to the work environment, clothing and the operator’s individual protective equipment as required by all the applicable regulations.
- It is advisable to keep a maintenance log for all maintenance tasks carried out on the actuator.

 **Prevent foreign bodies from entering the system by using a clean work surface in order to protect the delicate moving parts from being contaminated by dirt or foreign materials**

when assembling and disassembling, as this could cause a deterioration of the mechanical parts.

- Maintenance of the Portable Valve Actuators should be carried out by people who have been trained by **modec**.

Our “After Sales Service” department are ready to help in this respect.

- Systematically disconnect the actuator from the power feed (battery pack or mains) before carrying out any procedure that involves replacing, adjusting, servicing or disassembling the actuator or any of its parts.



- Every time maintenance is carried out, test the actuator afterwards to check it is working correctly.

Only use approved replacement parts and follow the manufacturer’s advice with regard to lubrication and waterproofing.

## 12. Problem solving

<b>Electric Portable Valve Actuator MC89</b>			
<b>Symptoms</b>	<b>Probable causes</b>	<b>Checks &amp; solutions</b>	<b>Repaired by</b>
The actuator doesn't start	Direction switch button is not activated	Press switch correctly to the left or the right	User
	Battery not properly in place	Insert the battery correctly	User
The actuator beeps once and stops	Battery pack is empty / not charged	Charge / change the battery pack	User
	Actuator overloaded (torque is too high)	Reduce load	User
	Actuator has overheated	Let it cool down a few minutes	User
The actuator beeps once and the led flashes continuously	Torque reaction safety has triggered	Release the On/Off switch, fix a torque reaction system and start again	User
The actuator beeps continuously	The motor is faulty	Contact a <b>modec</b> Service center	<b>modec</b> Distributor

<b>Revolution counter (optional)</b>					
<b>Symptom</b>	<b>Screen status</b>	<b>Probable causes</b>	<b>Checks</b>	<b>Solutions</b>	<b>Repaired by</b>
The counter doesn't give a reading	Off	Timer elapsed / automatic stop		Activate the “ON” button	User
		Flat battery	Check the state of the battery	Change the battery	User
		Screen is out of order	Check with a registered <b>modec</b> distributor	Change the screen	<b>modec</b> Distributor
The counter is on but doesn't count	On and not moving	Poor connection between the captor and the card	Check the sensor connection	Reconnect the sensor	User <b>modec</b> Distributor
		Captor and/or the card is out of order	Check with a registered <b>modec</b> distributor	Change the electronic card	<b>modec</b> Distributor

## 13. Instruction Manual : modec Portable Valve Actuators

The Portable Valve Actuators user's manual videos





# Warranty

**modec** guarantees its equipment in accordance with the following conditions:

- During 12 months as of the delivery date, **modec** warrants its equipment against all material and manufacturing defects, except for consumable parts and elements which are out of order due to normal wear and tear further to standard use 8 hours per business day. During the aforementioned period, **modec** will replace or repair all parts acknowledged as defective by our departments, which parts shall have been promptly returned by the buyer to **modec** plants, all carriage costs and duties paid, enclosing a detailed description of the recorded breakdown and the warranty certificate.
- Components which were not manufactured by us come under the relevant manufacturer's warranty.

This warranty shall only be applicable if the machine is used with **modec** consumables. We hold no liability if our products are used in an abnormal manner.

## **AGREEMENT REVIEW**

Significant modifications in the Buyer's economic or financial situation, including the sale, transfer, pledge or contribution of the latter's business or assets, and if payment or acceptance of bill is not performed on the agreed date, even further to partial order performance, may entail revision of the conditions thereof and the overall credit conditions granted.

## **INTELLECTUAL PROPERTY**

We continue to hold all intellectual property rights to our projects, studies and documents which shall not be communicated, exploited or reproduced without our prior written authorization.

## **FORCE MAJEURE EVENT**

**modec** shall not be held responsible for any breach whatsoever of its contractual obligations that result from causes which are beyond our control such as, amongst others: fire, storms, flooding, earthquake, explosion, accident, strikes and/or industrial disputes, hostile actions, insurrection, war (declared or otherwise), rebellion, sabotage, epidemics, quarantine, impossibility of ensuring supplies of parts, raw materials or machinery, Government decision and legal actions.

## **APPLICABLE LAW**

The agreement shall be governed and construed in accordance with French law.

## **POWER OF JURISDICTION**

All disputes or litigation which have not been amicably settled shall be referred to the Commercial Court of Romans, acknowledged as sole competent jurisdiction by the contractors, including in the event of the introduction of third parties.

## **OTHER CONDITIONS**

Those of the Federation of Mechanical Industrialists of France.

# Notes

---

---

---

---

---

---

---

---

---

---

---

---

**Contact modec :  
MARVIN BAKER  
713-298-8100**

# Notes

---

---

---

---

---

---

---

---

---

---

---

---

---

---

---

---

---



**moddec**



**Contact: MARVIN BAKER**  
**713-298-8100**  
**marvin@modecman.com**